

FOR LEASE



CHACONAS GROUP
ANN ARBOR AREA



5000 Carpenter Road Ypsilanti, MI

31,320 SF of Flex Warehouse Space Available

Colliers Ann Arbor
1955 Pauline Blvd, Suite 400
Ann Arbor, MI 48103
734.994.3100
annarbor@colliers.com
colliersannarbor.com





FOR LEASE

31,320 SF of Flex Warehouse Space Available

PROPERTY HIGHLIGHTS

- ± 31,320 SF
- \$10 PSF NNN
- Excellent Opportunity to Lease Versatile Flex Space for Storage, Distribution, or Light Manufacturing
- Customer-Facing Office Area with Formal Entry, Lobby, Private Offices, Large Conference Room, Kitchen Area, and Ample Storage
- Three Distinct Warehouse Sections:
 - Original Warehouse with ±16' Ceilings and Two Short-Haul Delivery Truck Wells
 - Middle Warehouse Offering ±7,760 SF With 25' Ceilings at The Eaves, Semi-Truck Well, and One Short-Haul Truck Well
 - End Warehouse with ±15,368 SF, 42' Ceilings at the Eaves, and Rolling Door Access
- Equipped with 425 Amps of 3-Phase Power and Sprinkler System
- Ample Parking for Employees and Visitors
- Conveniently Located on Carpenter Road Near US-23 and I-94 Interchange with Easy Access to Major Thoroughfares, Downtown Ann Arbor, and Surrounding Communities
- Signage Available and Locally Owned and Managed



CHACONAS GROUP
ANN ARBOR AREA



FOR LEASE

31,320 SF of Flex Warehouse Space Available

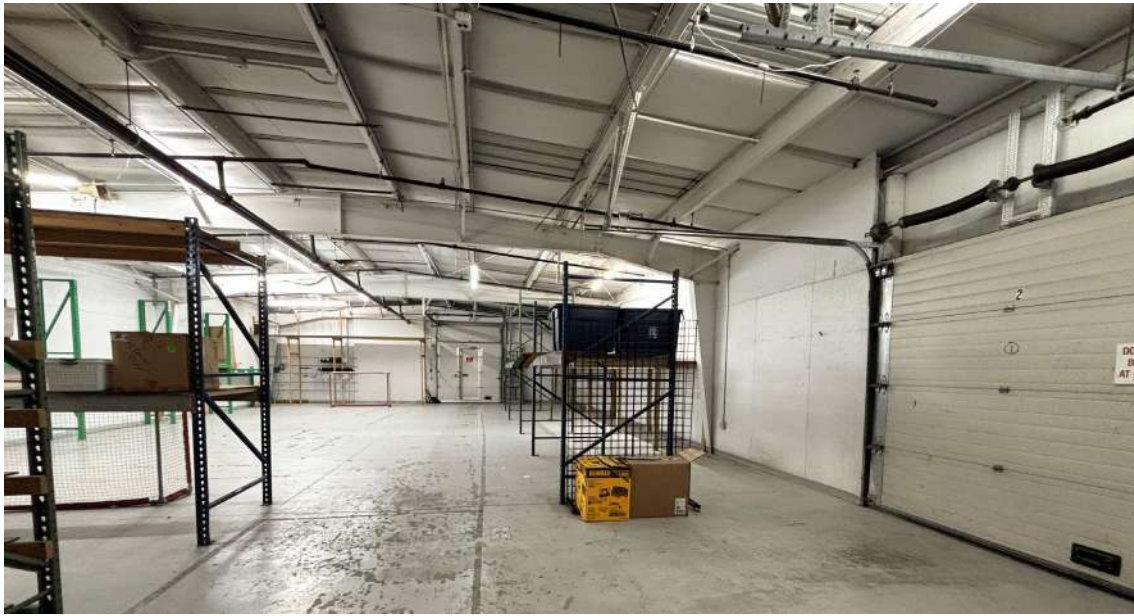

FOR LEASE

31,320 SF of Flex Warehouse Space Available



CHACONAS GROUP
ANN ARBOR AREA



FOR LEASE

31,320 SF of Flex Warehouse Space Available



CHACONAS GROUP
ANN ARBOR AREA



CHACONAS GROUP
ANN ARBOR AREA



FOR LEASE

31,320 SF of Flex Warehouse Space Available

E MORGAN ROAD

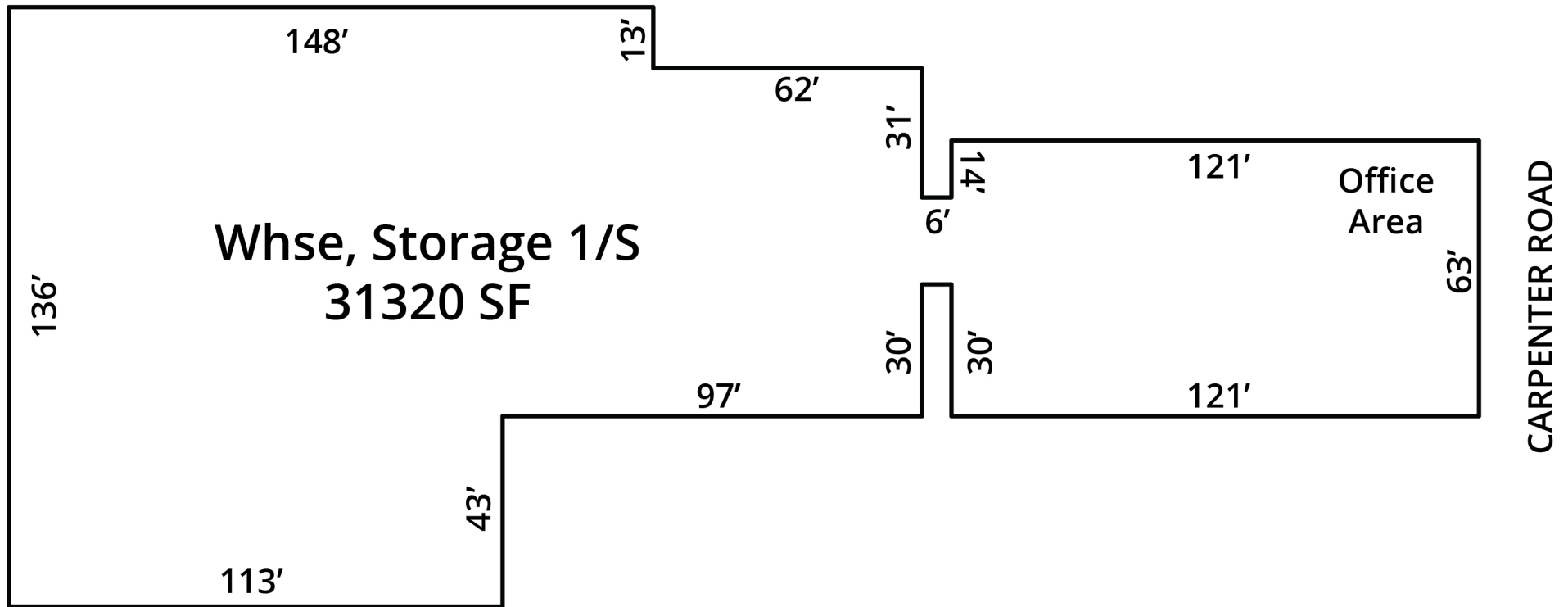

FLOOR PLAN

31,320 SF of Flex Warehouse Space Available



CHACONAS GROUP
ANN ARBOR AREA



AERIAL MAP

31,320 SF of Flex Warehouse Space Available



CHACONAS GROUP
ANN ARBOR AREA

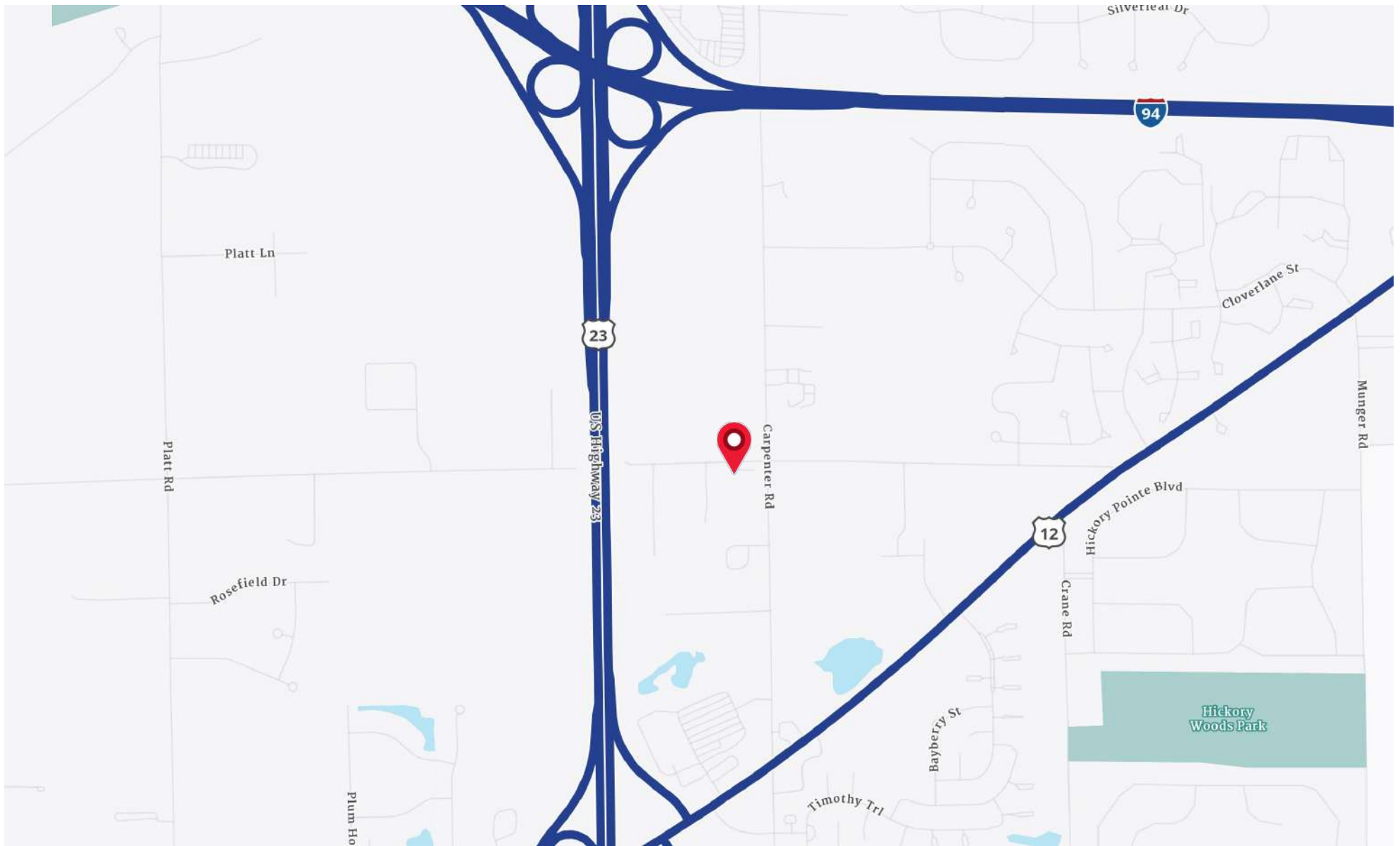

We have no reason to doubt the accuracy of information contained herein, but we cannot guarantee it. All information should be verified prior to purchase and/or lease.

LOCATION MAP

31,320 SF of Flex Warehouse Space Available



CHACONAS GROUP
ANN ARBOR AREA