

### BUILDING SUMMARY

MINIMUM CLEAR HEIGHT	±22'-9"
MAXIMUM CLEAR HEIGHT	±26'-10"
SPRINKLERED	YES
CONDITIONED WAREHOUSE	NO
TYP. COLUMN SPACING	40'-0" x 40'-0"

### SUITE SUMMARY

OFFICE SF	6,802 SF
WAREHOUSE SF	176,137 SF
TOTAL SF	182,939 SF
OFFICE PERCENTAGE	4%



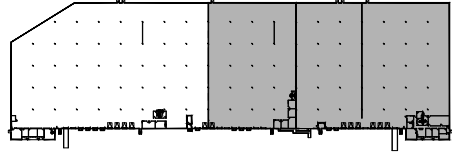

KEY PLAN

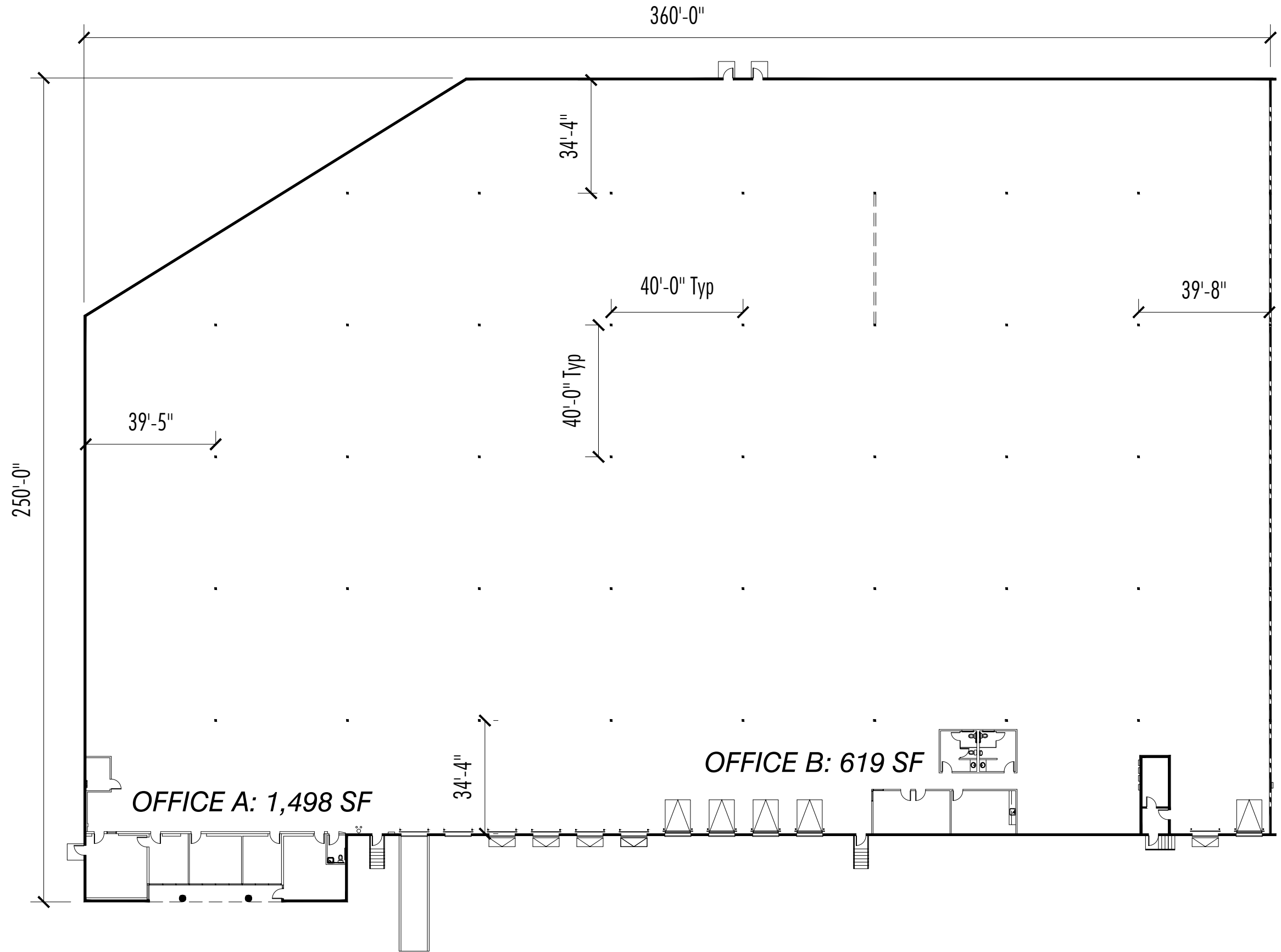

**BUILDING SUMMARY**

MINIMUM CLEAR HEIGHT	±22'-9"
MAXIMUM CLEAR HEIGHT	±26'-10"
SPRINKLERED	YES
CONDITIONED WAREHOUSE	NO
TYP. COLUMN SPACING	40'-0 x 40'-0

**SUITE SUMMARY**

OFFICE SF	2,117 SF
WAREHOUSE SF	78,459 SF
TOTAL SF	80,576 SF
OFFICE PERCENTAGE	3%

**OFFICE A: 1,498 SF**

**OFFICE B: 619 SF**



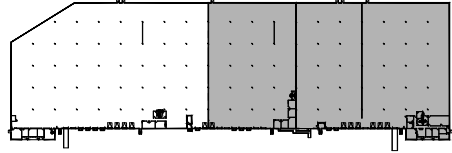

KEY PLAN

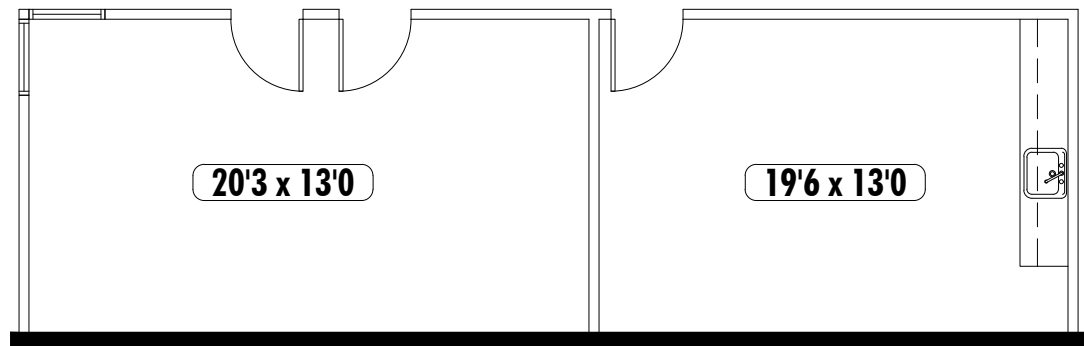
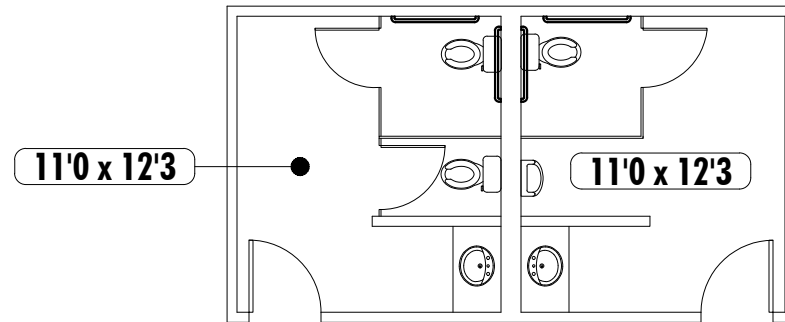

OFFICE B - 1,498 SF

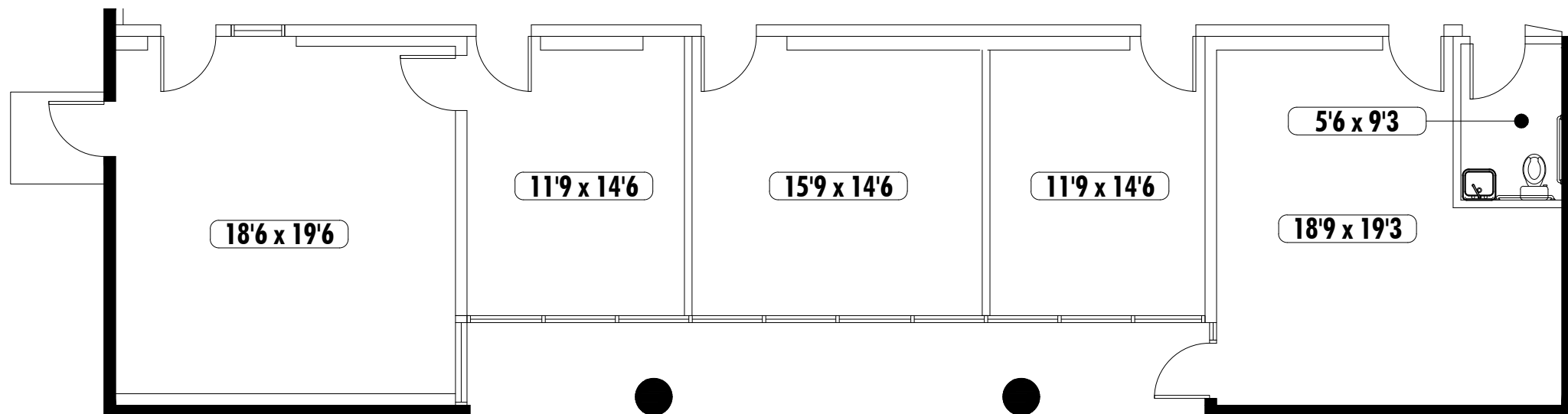

OFFICE A - 1,498 SF

**BUILDING SUMMARY**

MINIMUM CLEAR HEIGHT	±22'-9"
MAXIMUM CLEAR HEIGHT	±26'-10"
SPRINKLERED	YES
CONDITIONED WAREHOUSE	NO
TYP. COLUMN SPACING	40'-0 x 40'-0

**SUITE SUMMARY**

OFFICE SF	2,117 SF
WAREHOUSE SF	78,459 SF
TOTAL SF	80,576 SF
OFFICE PERCENTAGE	3%



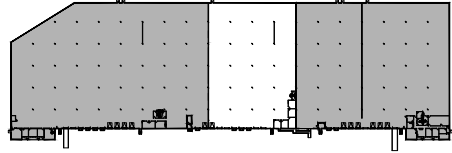

KEY PLAN

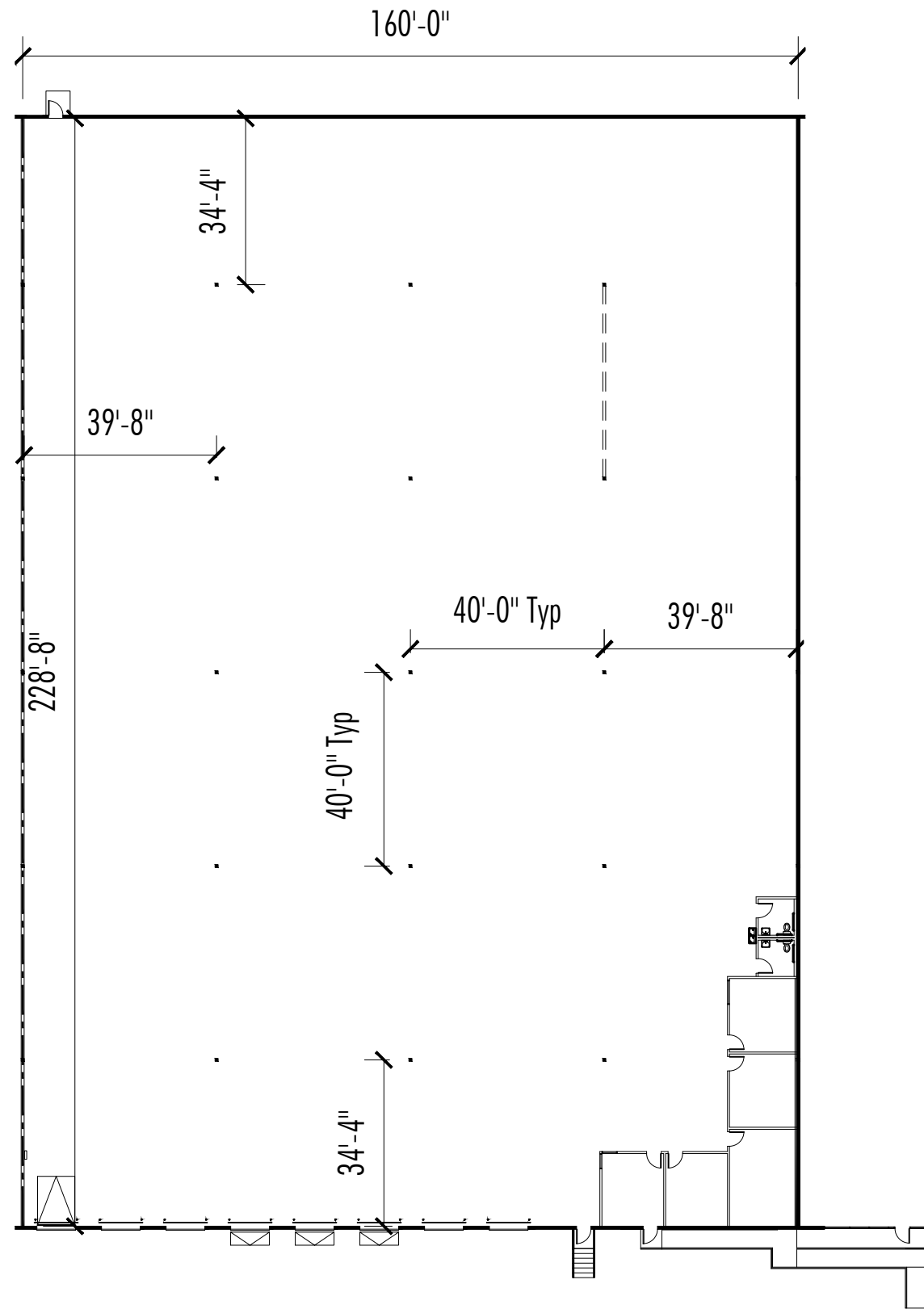

### BUILDING SUMMARY

MINIMUM CLEAR HEIGHT	±22'-9"
MAXIMUM CLEAR HEIGHT	±26'-10"
SPRINKLERED	YES
CONDITIONED WAREHOUSE	NO
TYP. COLUMN SPACING	40'-0 x 40'-0

### SUITE SUMMARY

OFFICE SF	1,348 SF
WAREHOUSE SF	34,904 SF
TOTAL SF	36,252 SF
OFFICE PERCENTAGE	4%

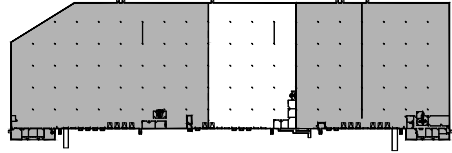

KEY PLAN

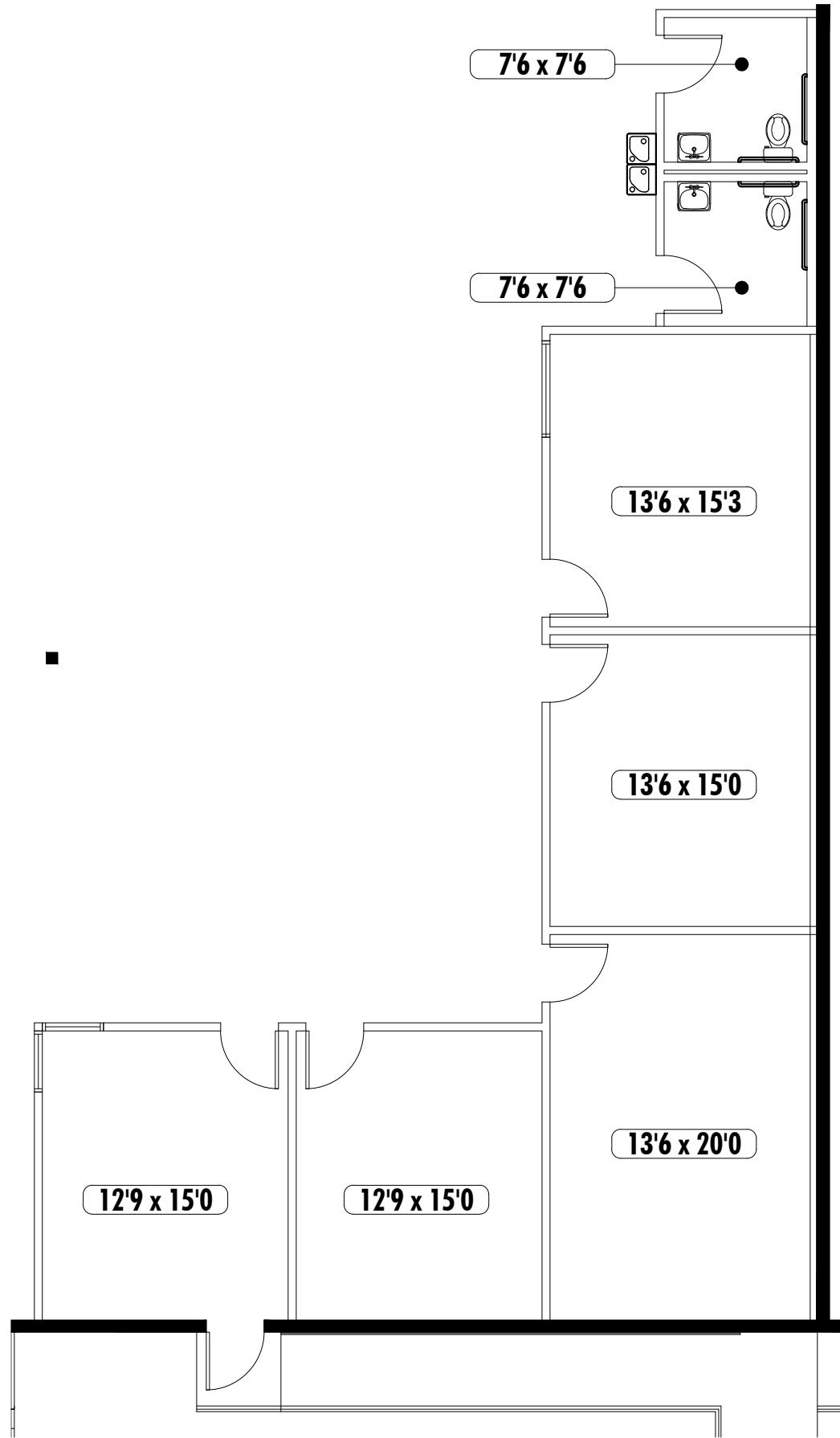

### BUILDING SUMMARY

MINIMUM CLEAR HEIGHT	±22'-9"
MAXIMUM CLEAR HEIGHT	±26'-10"
SPRINKLERED	YES
CONDITIONED WAREHOUSE	NO
TYP. COLUMN SPACING	40'-0" x 40'-0"

### SUITE SUMMARY

OFFICE SF	1,348 SF
WAREHOUSE SF	34,904 SF
TOTAL SF	36,252 SF
OFFICE PERCENTAGE	4%

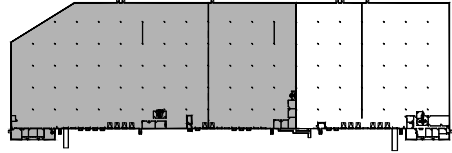

KEY PLAN

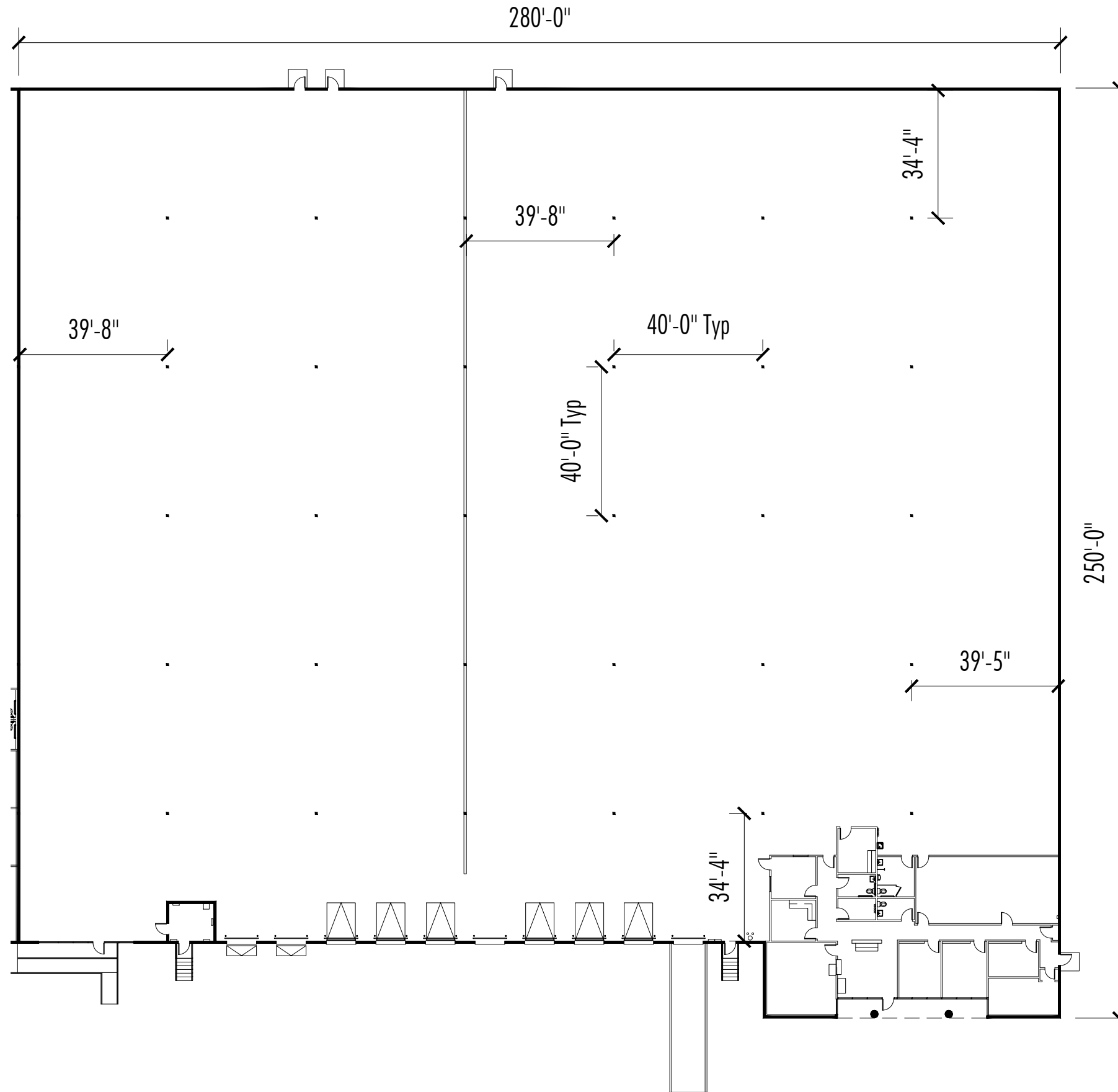

**BUILDING SUMMARY**

MINIMUM CLEAR HEIGHT	±22'-9"
MAXIMUM CLEAR HEIGHT	±26'-10"
SPRINKLERED	YES
CONDITIONED WAREHOUSE	NO
TYP. COLUMN SPACING	40'-0 x 40'-0

**SUITE SUMMARY**

OFFICE SF	3,337 SF
WAREHOUSE SF	62,774 SF
TOTAL SF	66,111 SF
OFFICE PERCENTAGE	5%



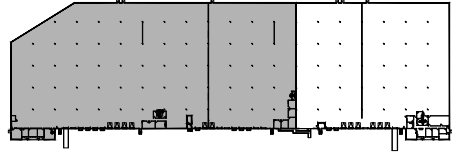

KEY PLAN

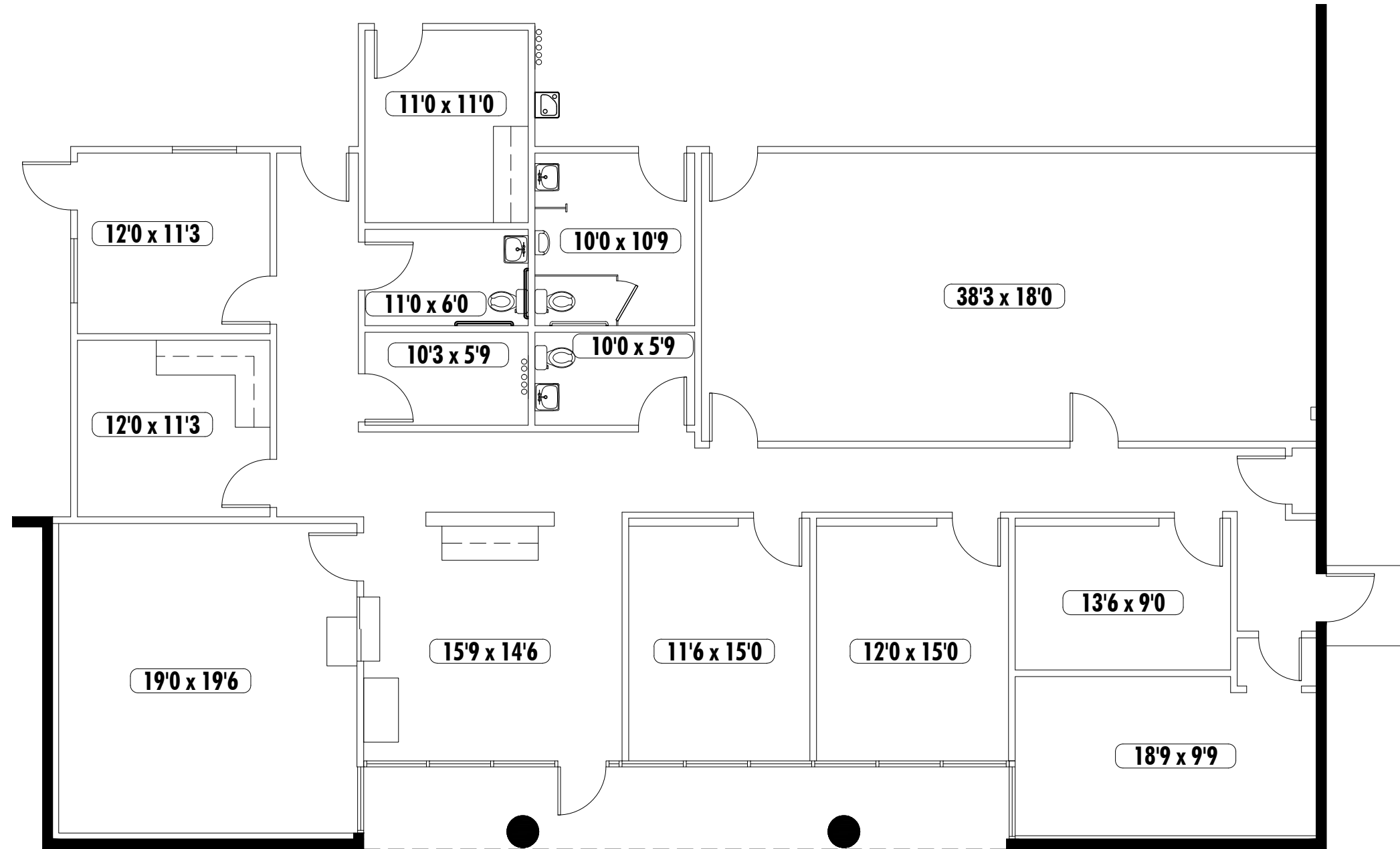

**BUILDING SUMMARY**

MINIMUM CLEAR HEIGHT	±22'-9"
MAXIMUM CLEAR HEIGHT	±26'-10"
SPRINKLERED	YES
CONDITIONED WAREHOUSE	NO
TYP. COLUMN SPACING	40'-0 x 40'-0

**SUITE SUMMARY**

OFFICE SF	3,337 SF
WAREHOUSE SF	62,774 SF
TOTAL SF	66,111 SF
OFFICE PERCENTAGE	5%

