

# 7911 W USTICK ROAD

OFFICE SPACE FOR SALE BOISE | IDAHO 83704



**\$194 PER SF | BASED ON 1ST & 2ND FLOOR SF ONLY,  
EXCLUDING 1,488 SF OF FINISHED BASEMENT**

**JOHN STEVENS**

208.947.0814

john@tokcommercial.com

Two-story office

Large monumental signage on Ustick Rd

Easy access to major roads and amenities

Ample on-site parking

2nd floor leased through 11/30/2027 at \$1,862/mo NNN

Tenant is RenaissanceRanch.net

Ground can be vacant at close of escrow (approx 2,170 SF)

Finished basement with restroom & shower  
(approx 1,488 SF)

**SALE PRICE:**

\$845,000

**SUBMARKET:**

Boise

**BLDG TYPE:**

Class B Office

**BLDG SIZE:**

5,828 SF

**LOT SIZE:**

0.48 Acres

**PROPERTY TAX 2024:**

\$7,692

**YEAR BUILT:**

1996

**ZONING:**

MX-1

CONTACT



HIGHLIGHTS



DETAILS



# SITE & FLOOR PLAN

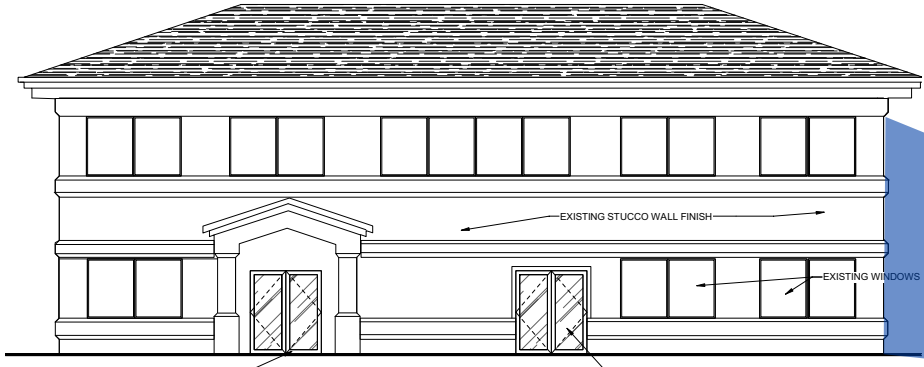

**ELEVATION**

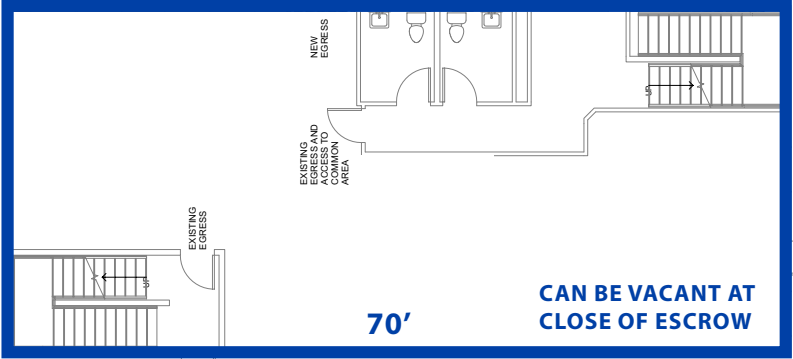
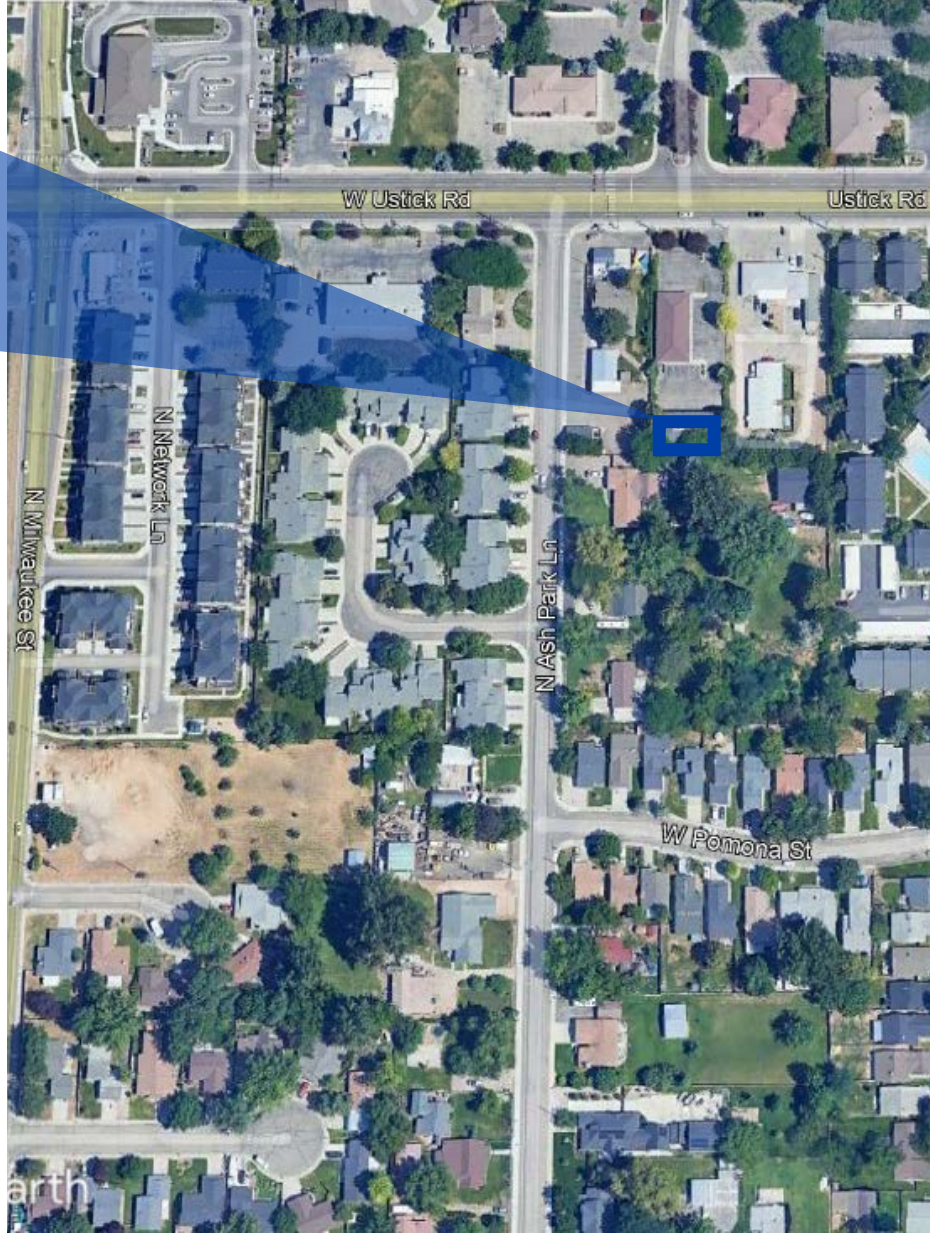

**FIRST FLOOR**

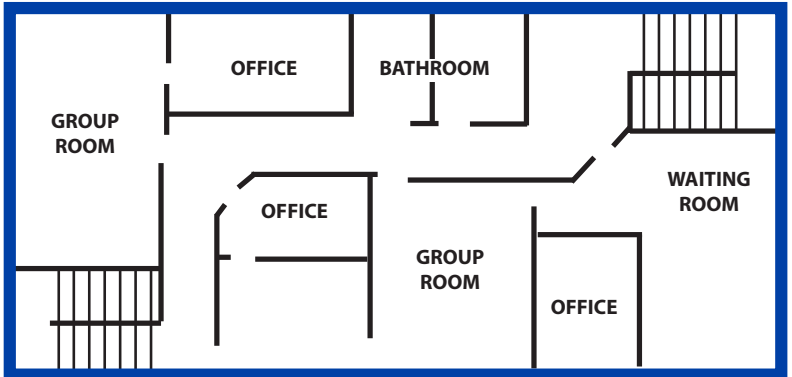

**SECOND FLOOR**

**2ND FLOOR LEASED THROUGH 11/30/2027 | \$1,862.58/MO**

# FLOOR PLAN

## BASEMENT FLOOR PLAN

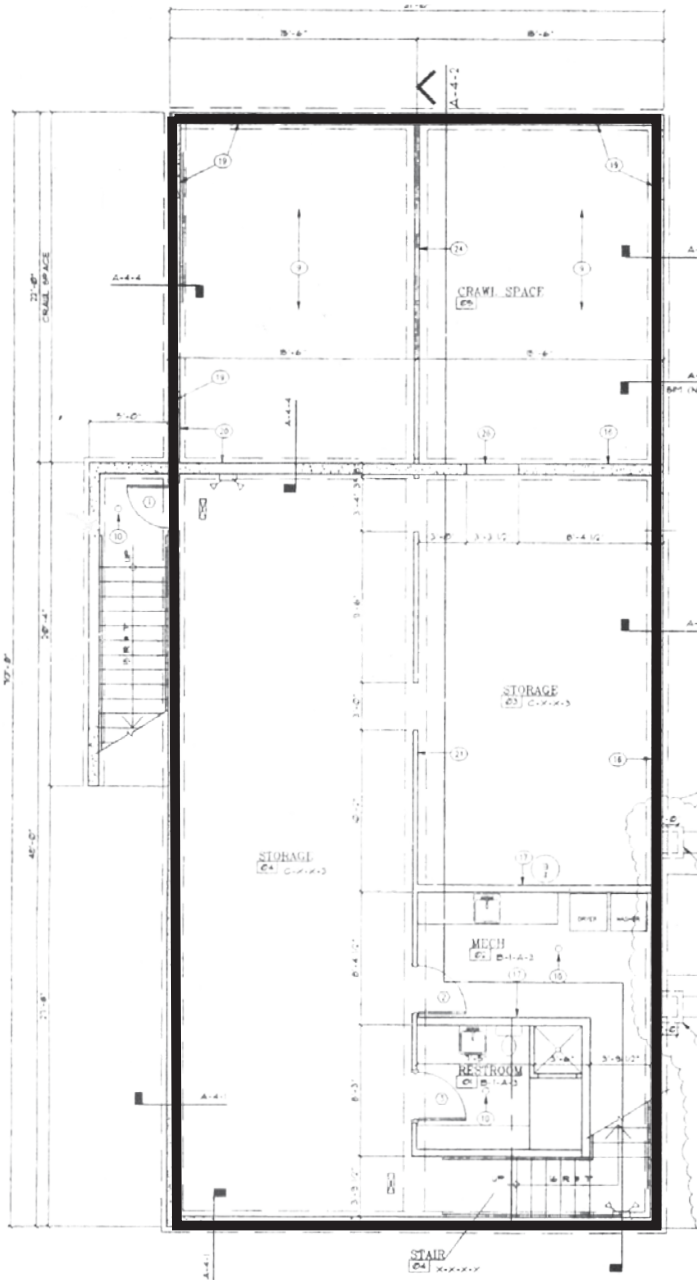

## ORIGINAL 1ST FLOOR PLAN

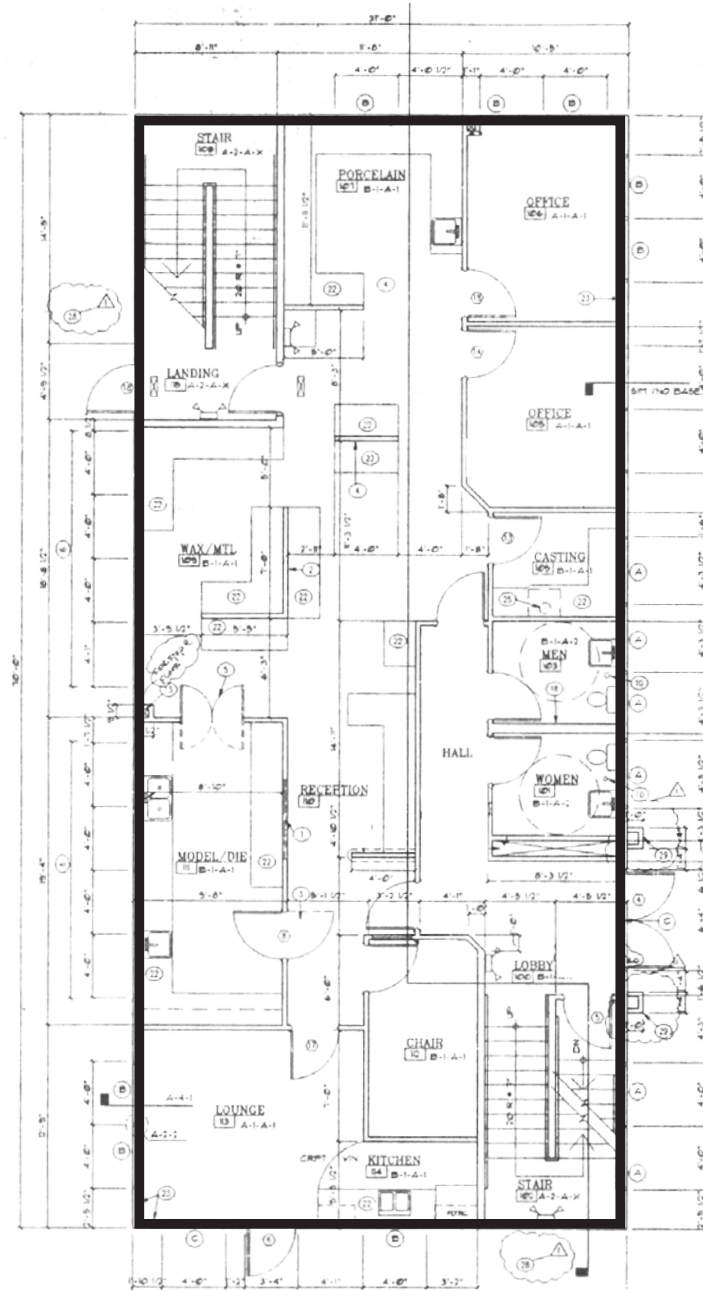



GROUND FLOOR



GROUND FLOOR

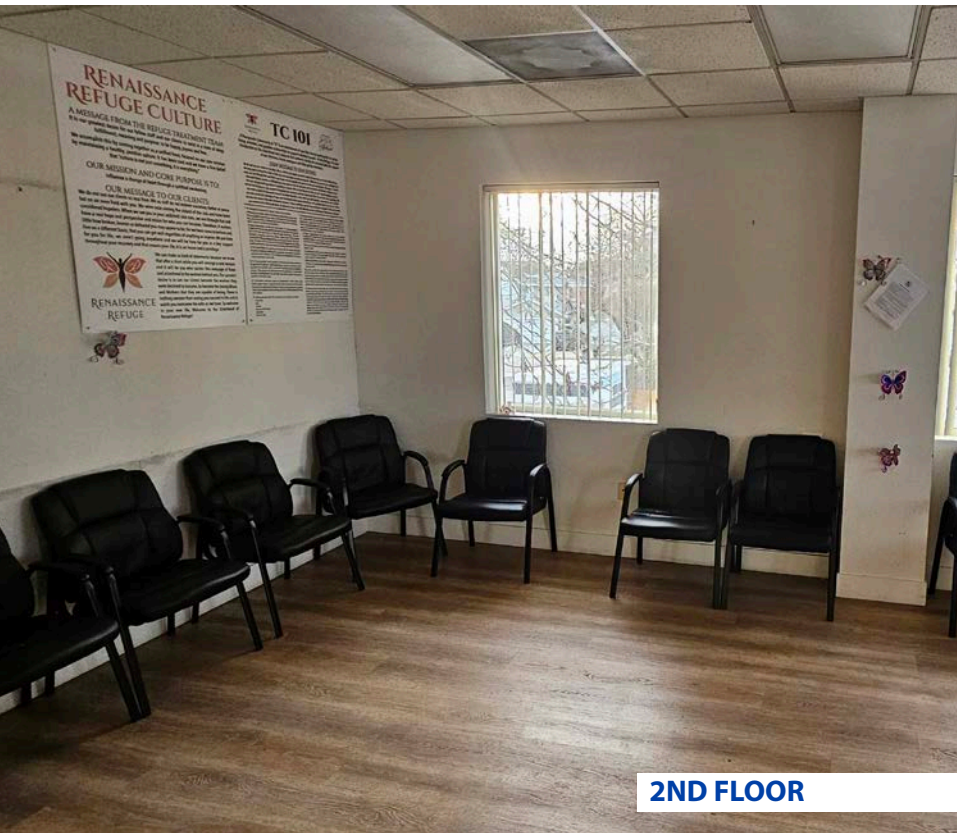

2ND FLOOR

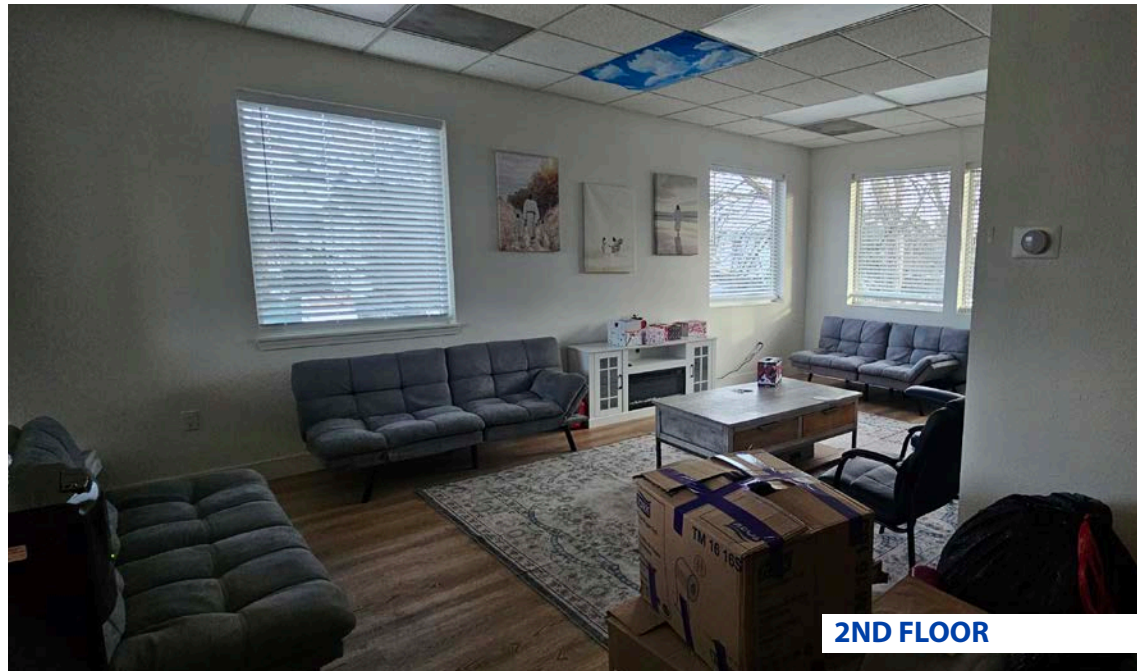

2ND FLOOR



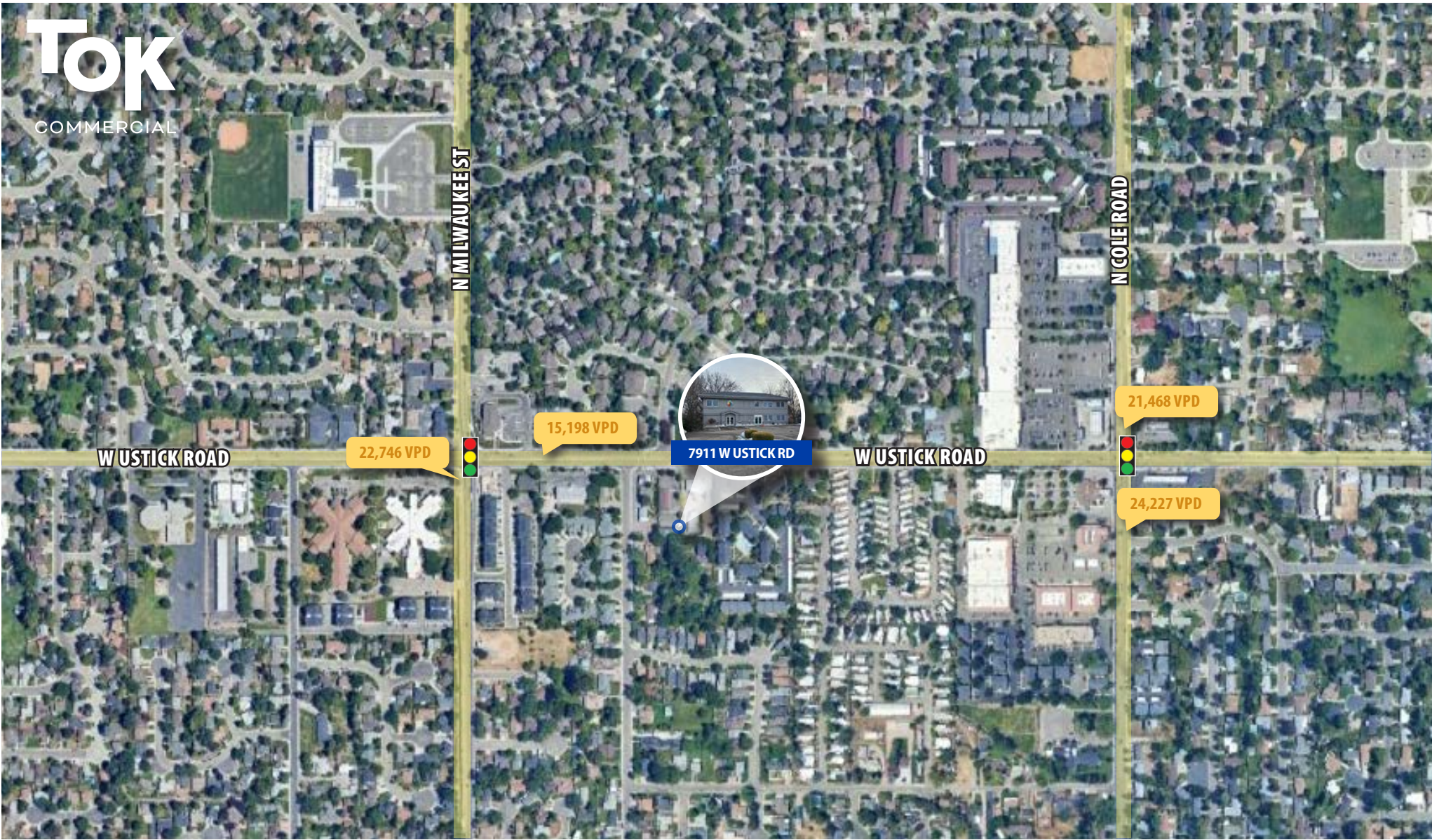

**1 MILE RADIUS**

POPULATION	EST. EMPLOYEES	AVG. HOUSEHOLD INC.
<b>14,515</b>	<b>3,912</b>	<b>\$78,183</b>
1 MI. RADIUS	1 MI. RADIUS	1 MI. RADIUS

**3 MILE RADIUS**

POPULATION	EST. EMPLOYEES	AVG. HOUSEHOLD INC.
<b>113,850</b>	<b>50,981</b>	<b>\$76,604</b>
3 MI. RADIUS	3 MI. RADIUS	3 MI. RADIUS

**5 MILE RADIUS**

POPULATION	EST. EMPLOYEES	AVG. HOUSEHOLD INC.
<b>234,447</b>	<b>127,278</b>	<b>\$83,507</b>
5 MI. RADIUS	5 MI. RADIUS	5 MI. RADIUS

# TOK

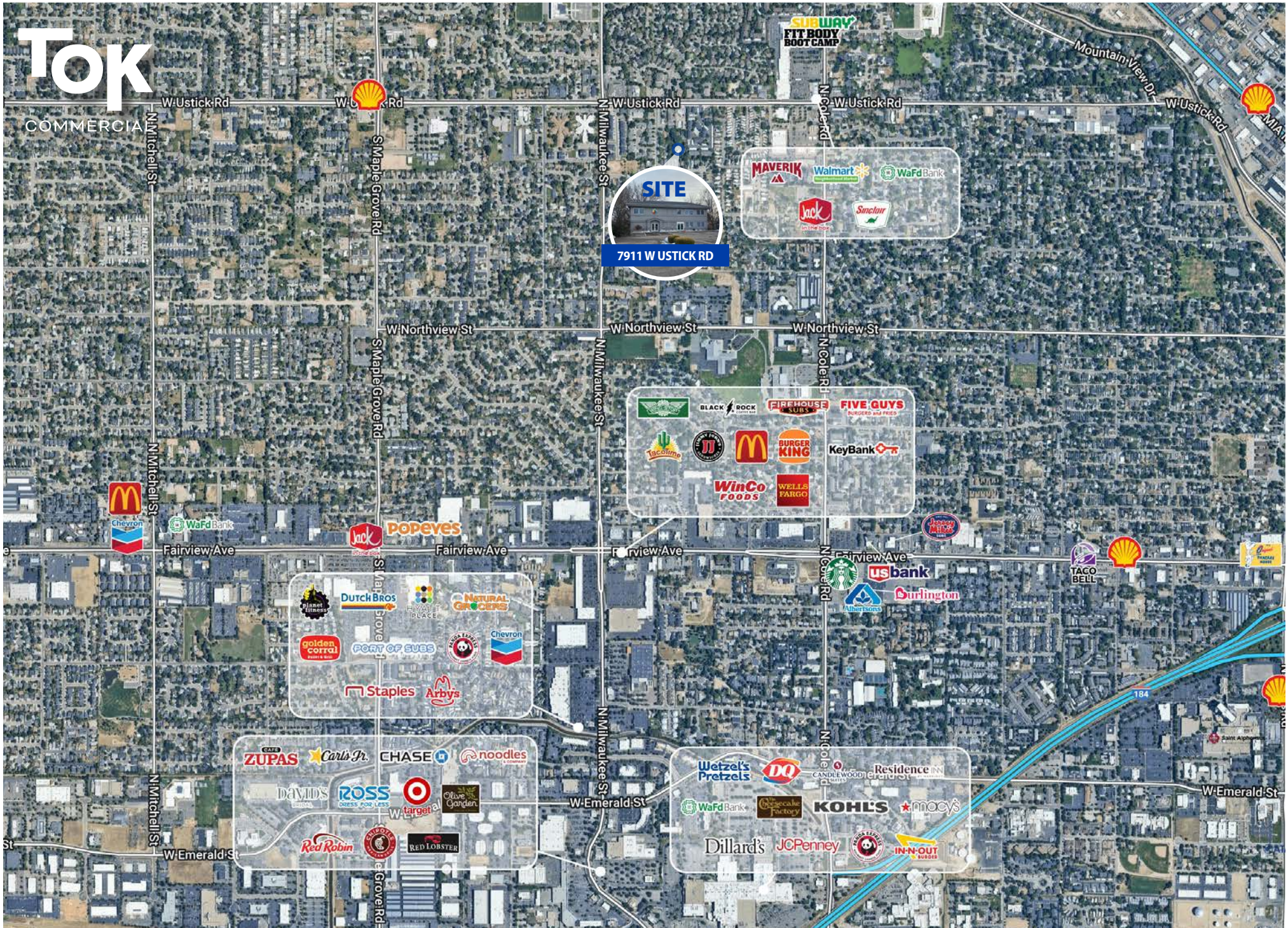

**SITE**  
7911 W USTICK RD

MAVERIK  
Walmart  
WafD Bank  
Jack  
Santitas

BLACK ROCK  
FIREHOUSE SUBS  
FIVE GUYS  
Taco Time  
McDonald's  
BURGER KING  
KeyBank  
WinCo FOODS  
WELLS FARGO

Planet Fitness  
Dutch Bros  
NATURAL GROCERS  
golden corral  
PORT OF EVES  
Staples  
Arbys

ZUPAS  
Carls Jr.  
CHASE  
noodles  
DAVID'S  
ROSS  
target  
Olive Garden  
Red Robin  
RED LOBSTER

Wetzel's Pretzels  
DQ  
Residence Inn  
WafD Bank  
Chicagoable Factory  
KOHL'S  
macy's  
Dillard's  
JCPenney  
IN-N-OUT