



OFFICE SPACE FOR LEASE

OFFICE SPACE FOR LEASE | 5407 S CAMPBELL AVE, SPRINGFIELD, MO 65810

- Located at the corner of Campbell and Plainview
- Excellent visibility
- Easy access to James River Freeway

EST. 1909

2225 S. Blackman Road
Springfield, MO 65809
417.881.0600
rbmurray.com

Ryan Murray, SIOR, CCIM, LEED AP, CPM
417.881.0600
ryan@rbmurray.com

R.B. | MURRAY COMPANY
SINCE 1909
COMMERCIAL & INDUSTRIAL REAL ESTATE

Executive Summary



PROPERTY SUMMARY

Monthly Estimated Rent:	\$1,700.00
Available SF:	1,800 SF
Lease Rate:	\$1,700 per month (MG)
Lot Size:	0.4 Acres
Building Size:	3,600 SF
Year Built:	1988
Zoning:	GC - General Commercial

The information listed above has been obtained from sources we believe to be reliable; however, we accept no responsibility for its accuracy.

PROPERTY OVERVIEW

Office space available for lease on South Campbell. The property is located on one of Springfield's busiest thoroughfares. The property is in a prime location with easy access to James River Freeway and surrounded by many local and national retailers. Modified Gross Lease - Tenant responsible for own monthly utilities, and increases in taxes and insurance. Contact listing agent for more information.

PROPERTY HIGHLIGHTS

- High traffic counts and great visibility
- Located on South Campbell just north of Plainview
- South Springfield area is experiencing new growth
- Tenant pays own utilities, and increases in taxes and insurance

EST. 1909

OFFICE SPACE
FOR LEASE

5407 S CAMPBELL AVE, SPRINGFIELD, MO 65810
OFFICE SPACE FOR LEASE



Available Spaces

Lease Rate: \$1,700 PER MONTH (MG)

Lease Type: Modified Gross

SPACE	LEASE RATE	LEASE TYPE	SIZE (SF)	TERM	COMMENTS
D, E, & F	\$1,700 PER MONTH	Modified Gross	1,800 SF	Negotiable	1,800± SF office space for lease at \$1,700.00 per month (Modified Gross). Tenant responsible for own monthly utilities, and increases in taxes and insurance.

EST. 1909

OFFICE SPACE
FOR LEASE

5407 S CAMPBELL AVE, SPRINGFIELD, MO 65810
OFFICE SPACE FOR LEASE



Additional Photos



OFFICE SPACE
FOR LEASE

5407 S CAMPBELL AVE, SPRINGFIELD, MO 65810
OFFICE SPACE FOR LEASE



Floor Plans

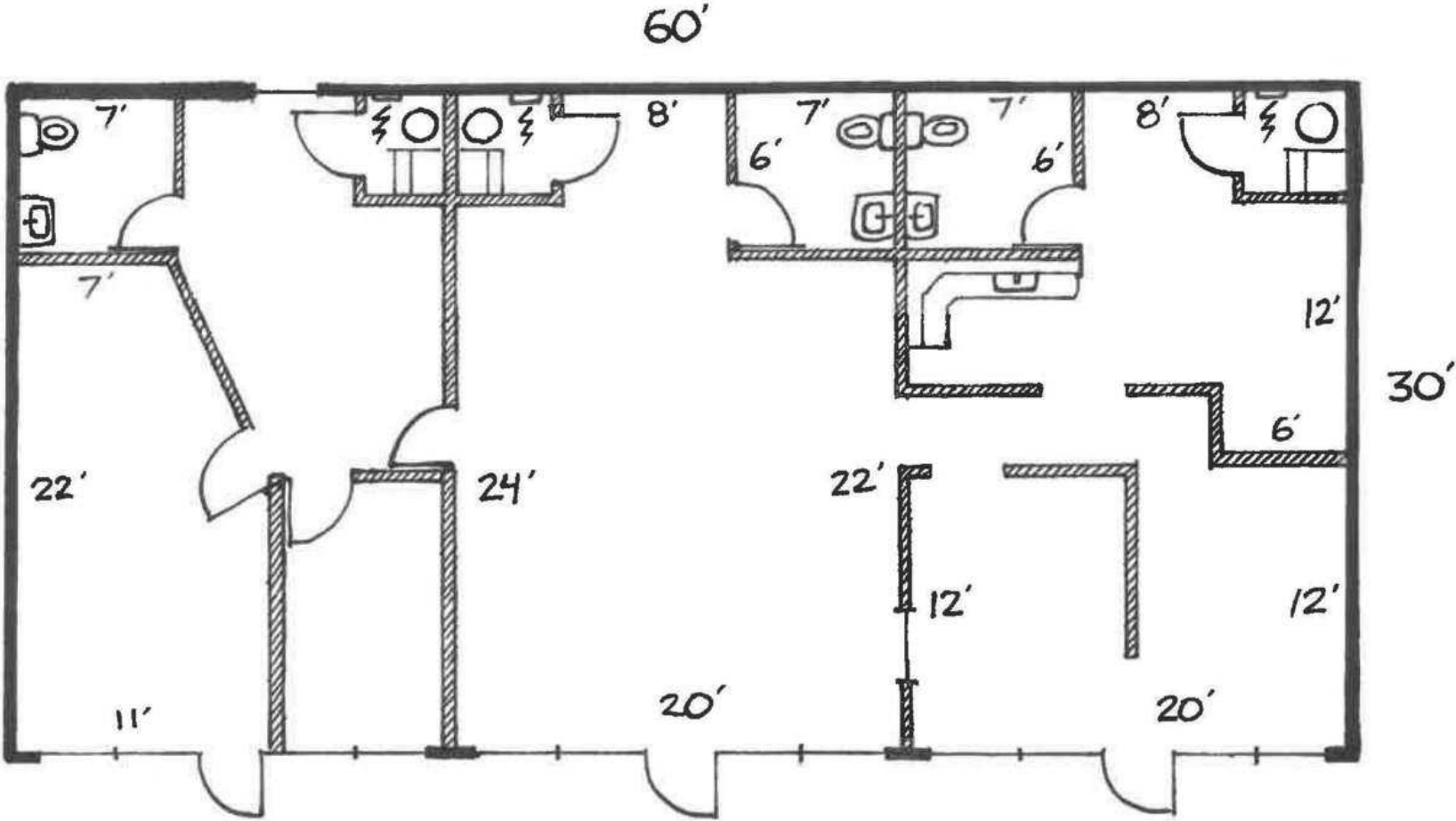

OFFICE SPACE
FOR LEASE

5407 S CAMPBELL AVE, SPRINGFIELD, MO 65810
OFFICE SPACE FOR LEASE



Retailer Map



Ryan Murray, SIOR, CCIM, LEED AP, CPM | 417.881.0600 | ryan@rbmurray.com
2225 S. Blackman Road | Springfield, MO 65809 | 417.881.0600

R.B. | MURRAY COMPANY
COMMERCIAL & INDUSTRIAL REAL ESTATE

OFFICE SPACE
FOR LEASE

5407 S CAMPBELL AVE, SPRINGFIELD, MO 65810
OFFICE SPACE FOR LEASE



Location Map

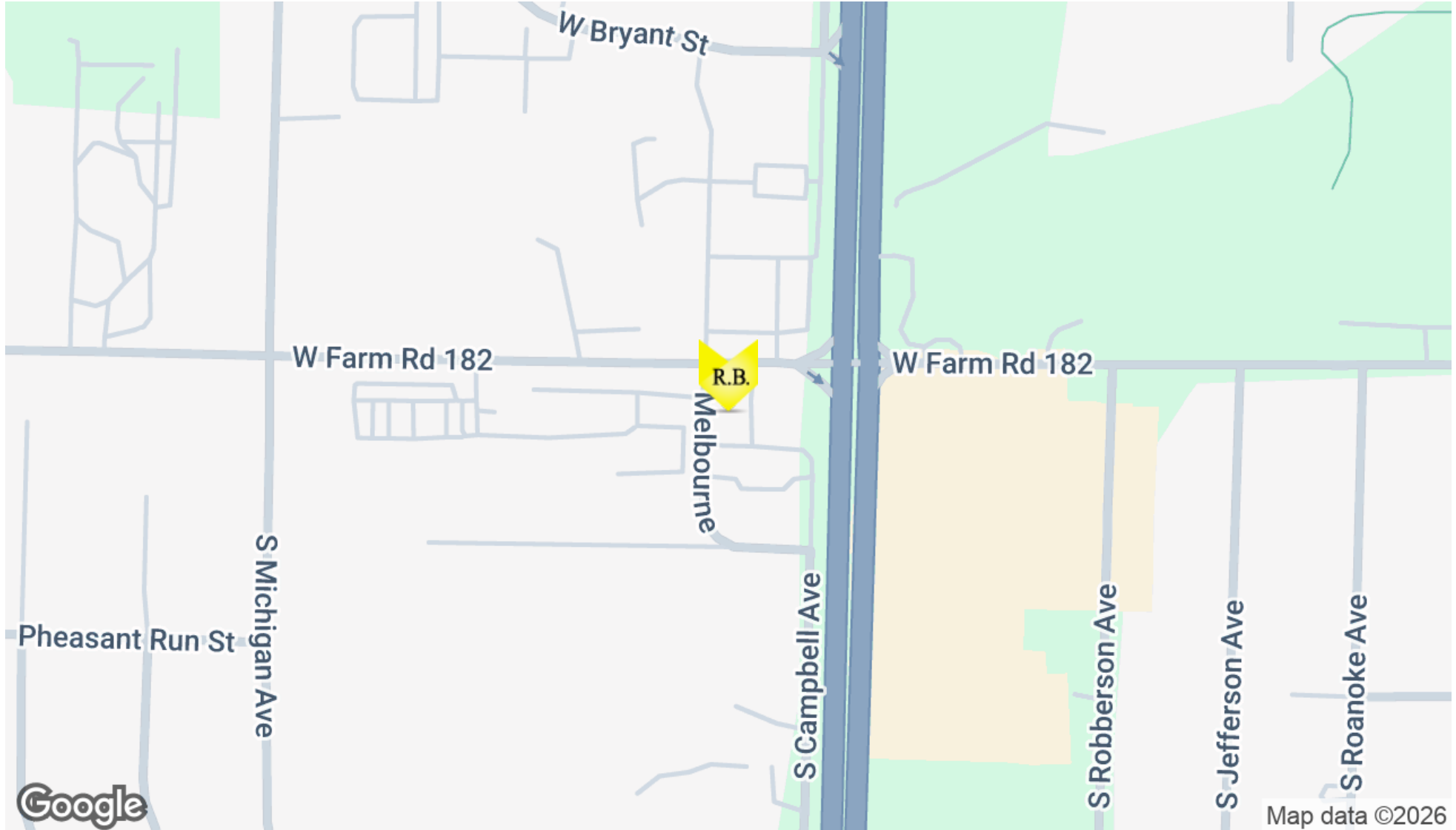

Ryan Murray, SIOR, CCIM, LEED AP, CPM | 417.881.0600 | ryan@rbmurray.com
2225 S. Blackman Road | Springfield, MO 65809 | 417.881.0600

R.B. | MURRAY COMPANY
COMMERCIAL & INDUSTRIAL REAL ESTATE

OFFICE SPACE
FOR LEASE

5407 S CAMPBELL AVE, SPRINGFIELD, MO 65810
OFFICE SPACE FOR LEASE



Demographics Map & Report

	0.3 MILES	0.5 MILES	1 MILE
POPULATION			
Total Population	702	2,198	7,811
Average Age	40	40	42
Average Age (Male)	39	39	40
Average Age (Female)	41	41	43
HOUSEHOLDS & INCOME			
Total Households	281	883	3,247
# of Persons per HH	2.5	2.5	2.4
Average HH Income	\$125,948	\$120,123	\$113,864
Average House Value	\$361,976	\$342,651	\$336,045

2020 American Community Survey (ACS)

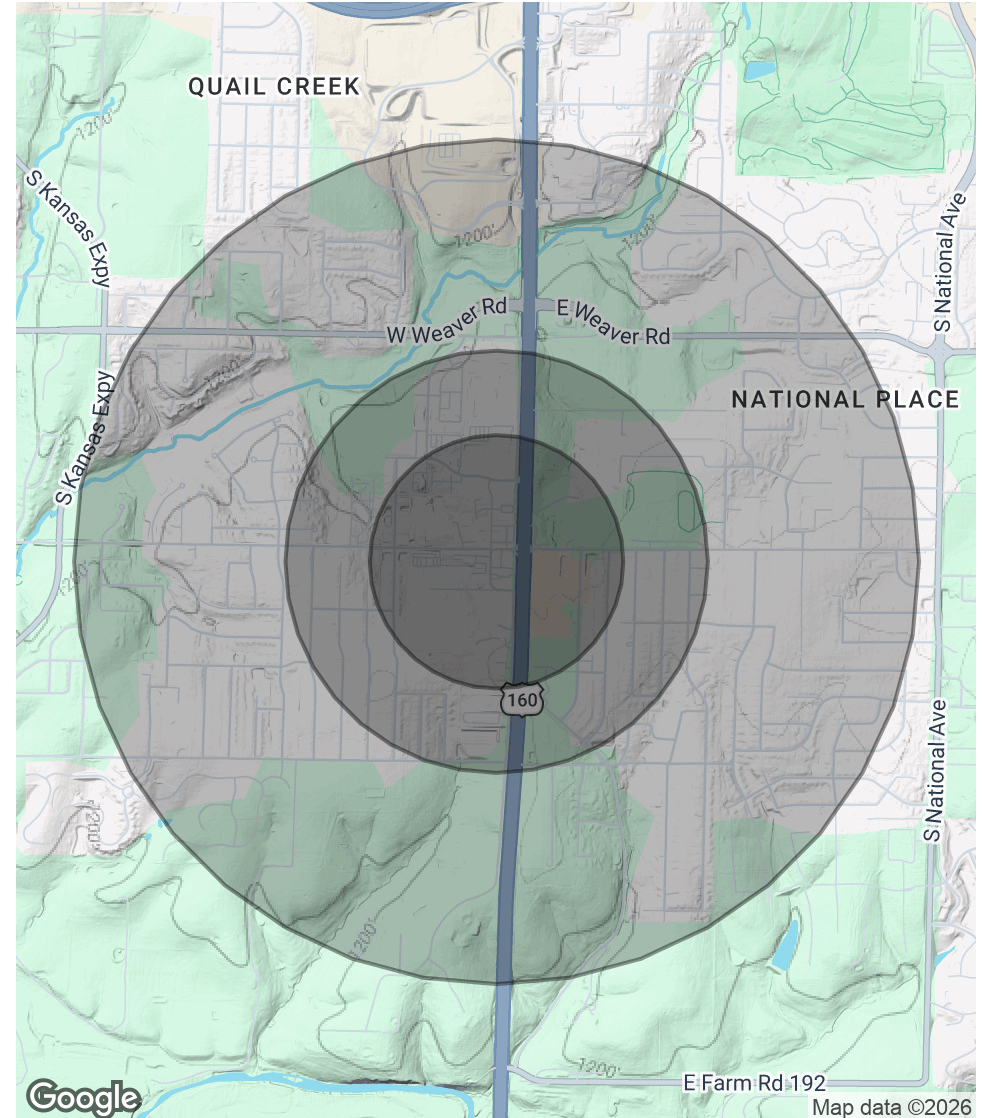

Advisor Bio

RYAN MURRAY, SIOR, CCIM, LEED AP, CPM
Chief Executive Officer



2225 S. Blackman Road
Springfield, MO 65809

T 417.881.0600
ryan@rbmurray.com
MO #2007030465

Professional Background

Ryan Murray joined R.B. Murray Company after graduating with Distinction Honors with a B.A. in Business Administration, and obtaining the Leeds School of Business Real Estate Certificate, from the University of Colorado. He was later named Vice President, specializing in the sales & leasing of office, retail, and industrial properties. Mr. Murray also oversees R.B. Murray Company's property management & receivership divisions.

Recently Mr. Murray obtained the Society of Industrial and Office Realtors (SIOR) designation, a professional achievement for highly qualified commercial real estate practitioners with a strong transactional history in brokerage. SIOR individual members are the best in the commercial real estate industry, and the top-producers in their field. SIOR members are in more than 630 cities and 33 countries worldwide, and are recognized as top producing professionals – closing on average more than 30 transactions per year, and have met stringent production, education, and ethical requirements.

Mr. Murray has achieved the Certified Commercial Investment Member Designation (CCIM), and was one of the state's first commercial real estate professionals to achieve Leadership in Energy and Environmental Design Accredited Professional (LEED AP) status. As a Certified Commercial Investment Member (CCIM) Mr. Murray is a recognized expert in the disciplines of commercial and investment real estate, and as a LEED AP Mr. Murray has demonstrated a thorough understanding of green building practices and principles and the LEED Rating System.

Mr. Murray has also earned Certified Property Manager® (CPM®) designation from the Institute of Real Estate Management (IREM®), an affiliate of the National Association of REALTORS®. The CPM® designation is awarded to real estate managers who have met the Institute's rigorous requirements in the areas of professional education, examination and experience. CPM® Members must also abide by a rigorous Code of Professional Ethics that is strictly enforced by the Institute.

Mr. Murray currently serves as a director on the OTC Foundation Board and the Rotary Club of Springfield Southeast Board, is a past member of the Board of Directors for the Make-A-Wish® Foundation of Missouri, and a graduate of the Leadership Springfield program. Mr. Murray lives in Springfield with his wife Maggie and their son & daughter.

Memberships & Affiliations

SIOR, CCIM, LEED AP, CPM

EST. 1909