

ACUITY HOLDINGS CONDO DEVELOPMENT

OTSEGO, MN

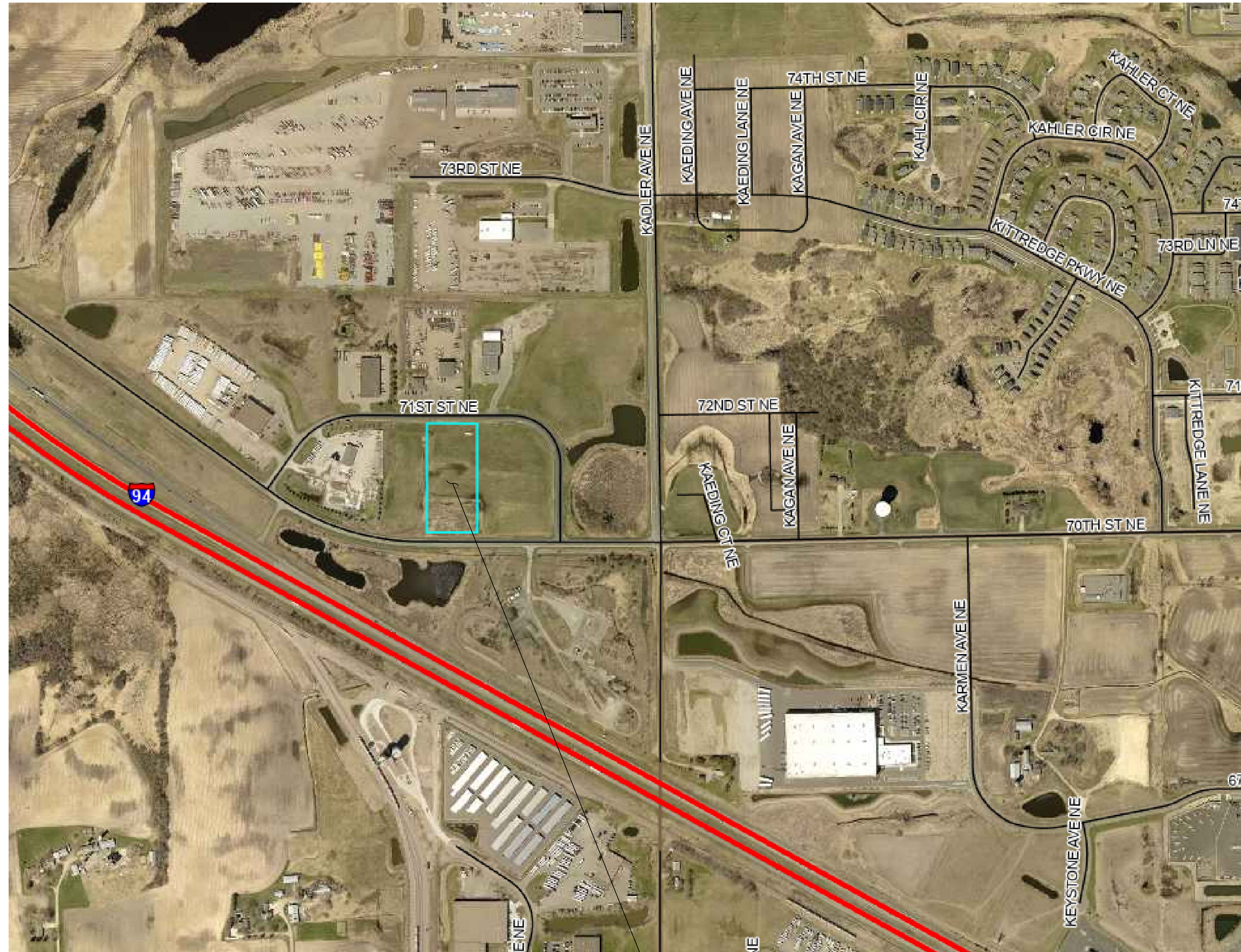

PROJECT AREA (APPROX.)

SHEET INDEX

- C1 - TITLE SHEET
- C2 - EXISTING CONDITIONS
- C3 - SITE AND UTILITY PLAN
- C4 - GRADING AND EROSION CONTROL PLAN
- C5 - LANDSCAPING PLAN
- C6 - STANDARD DETAILS
- C7-8 - SWPPP SHEETS

CITY OF OTSEGO, CITY ENGINEER _____ DATE _____

I HEREBY CERTIFY THAT THIS PLAN, SPECIFICATION, OR REPORT WAS PREPARED BY ME OR UNDER MY DIRECT SUPERVISION AND THAT I AM A DULY LICENSED PROFESSIONAL ENGINEER UNDER THE LAWS OF THE STATE OF MINNESOTA.

Krystle L. Bloch
 KRISTLE L. BLOCH
 7-16-2025 DATE 49893 LIC. NO.

ACUITY HOLDINGS
 OTSEGO DEVELOPMENT
 OTSEGO, MN
 TITLE

REVISIONS	NO.	DATE	DESCRIPTION
	1	9/17/25	UTILITY UPDATES PER MDL COMMENTS
	2	9/25/25	UTILITY UPDATES PER MDL COMMENTS
	3	3/9/26	POND/PARKING CHANGE, ADD SWPPP

GOVERNING STANDARDS: COUNTY OF WRIGHT STANDARDS, CEAM STANDARDS, CITY OF OTSEGO STANDARD CONTRACT DOCUMENTS AND TECHNICAL SPECIFICATIONS FOR UTILITY AND STREET CONSTRUCTION, LATEST EDITION OF THE MINNESOTA DEPARTMENT OF TRANSPORTATION "STANDARD SPECIFICATIONS FOR CONSTRUCTION", LATEST VERSION OF THE "MINNESOTA MANUAL OF UNIFORM TRAFFIC CONTROL DEVICES" (MMUTCD)

UTILITIES:
 GOPHER STATE ONE CALL
 (651) 454-0002
 gopherstateonecall.org

THE SUBSURFACE UTILITY INFORMATION IN THIS PLAN IS UTILITY QUALITY LEVEL D. THIS QUALITY LEVEL WAS DETERMINED ACCORDING TO THE GUIDELINES OF CI/ASCE 3-2, ENTITLED "STANDARD GUIDELINES FOR THE COLLECTION AND DEPICTION OF EXISTING SUBSURFACE UTILITY DATA."
 CONTRACTOR SHALL FIELD VERIFY EXACT LOCATIONS PRIOR TO COMMENCING CONSTRUCTION AS REQUIRED BY STATE LAW. GSOC INFORMATION ABOVE.

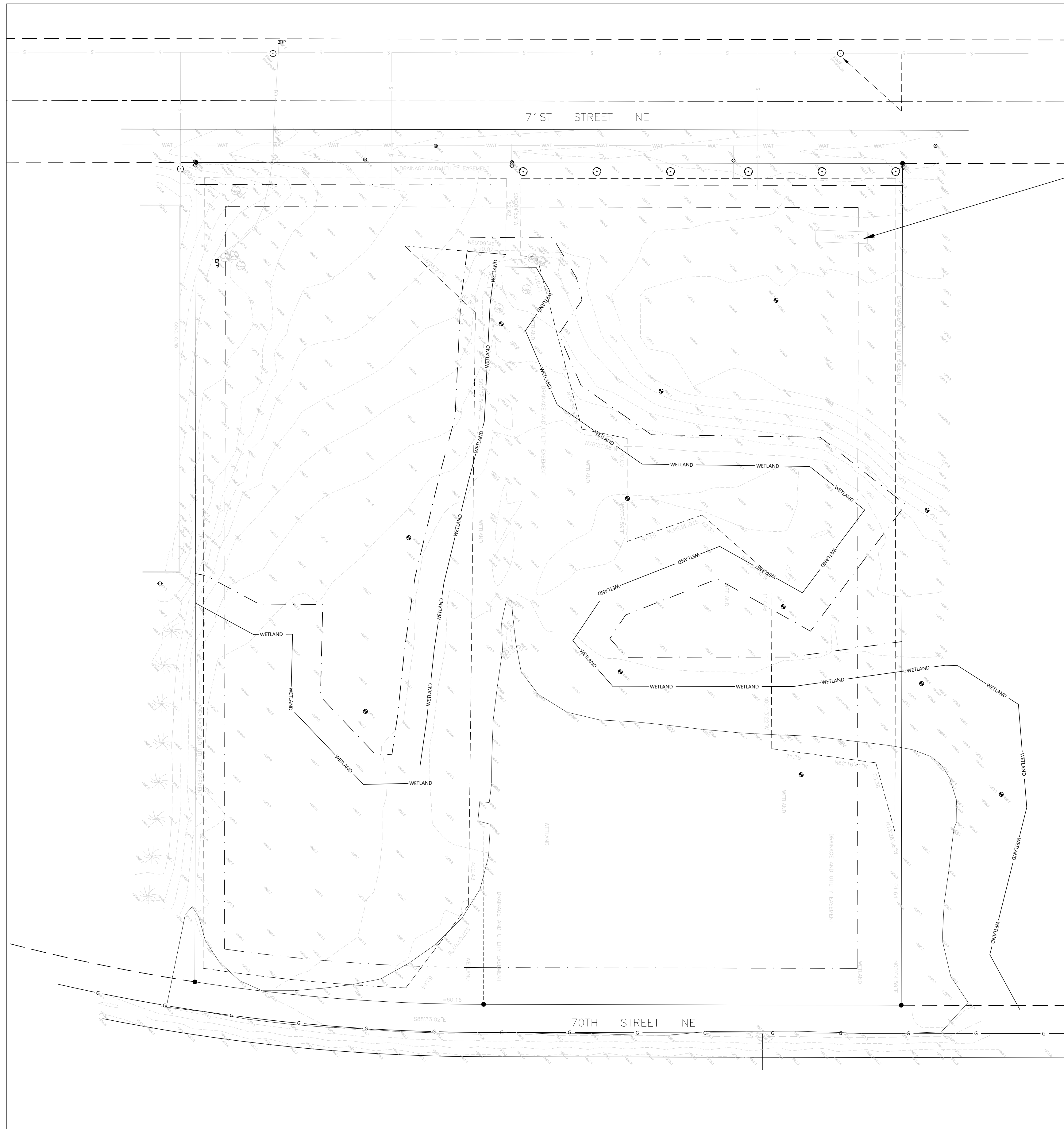

EXISTING TRAILER TO BE REMOVED PRIOR TO GRADING

JOB NO. 25-02

I HEREBY CERTIFY THAT THIS PLAN, SPECIFICATION, OR REPORT WAS PREPARED BY ME OR UNDER MY DIRECT SUPERVISION AND THAT I AM A DULY LICENSED PROFESSIONAL ENGINEER UNDER THE LAWS OF THE STATE OF MINNESOTA.

Krystle L. Bloch
 KRISTLE L. BLOCH
 7-16-2025 DATE 49893 LIC. NO.

ACUITY HOLDINGS
 OTSEGO DEVELOPMENT
 OTSEGO, MN
 EXISTING AND REMOVALS PLAN

NO.	DATE	BY	DESCRIPTION
1	9/17/25	KB	UTILITY UPDATES PER MDL COMMENTS
2	9/25/25	KB	UTILITY UPDATES PER MDL COMMENTS
3	3/9/26	KB	POND/PARKING CHANGE, ADD SWPPP

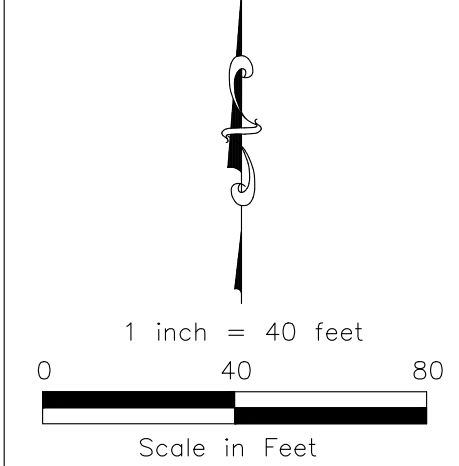

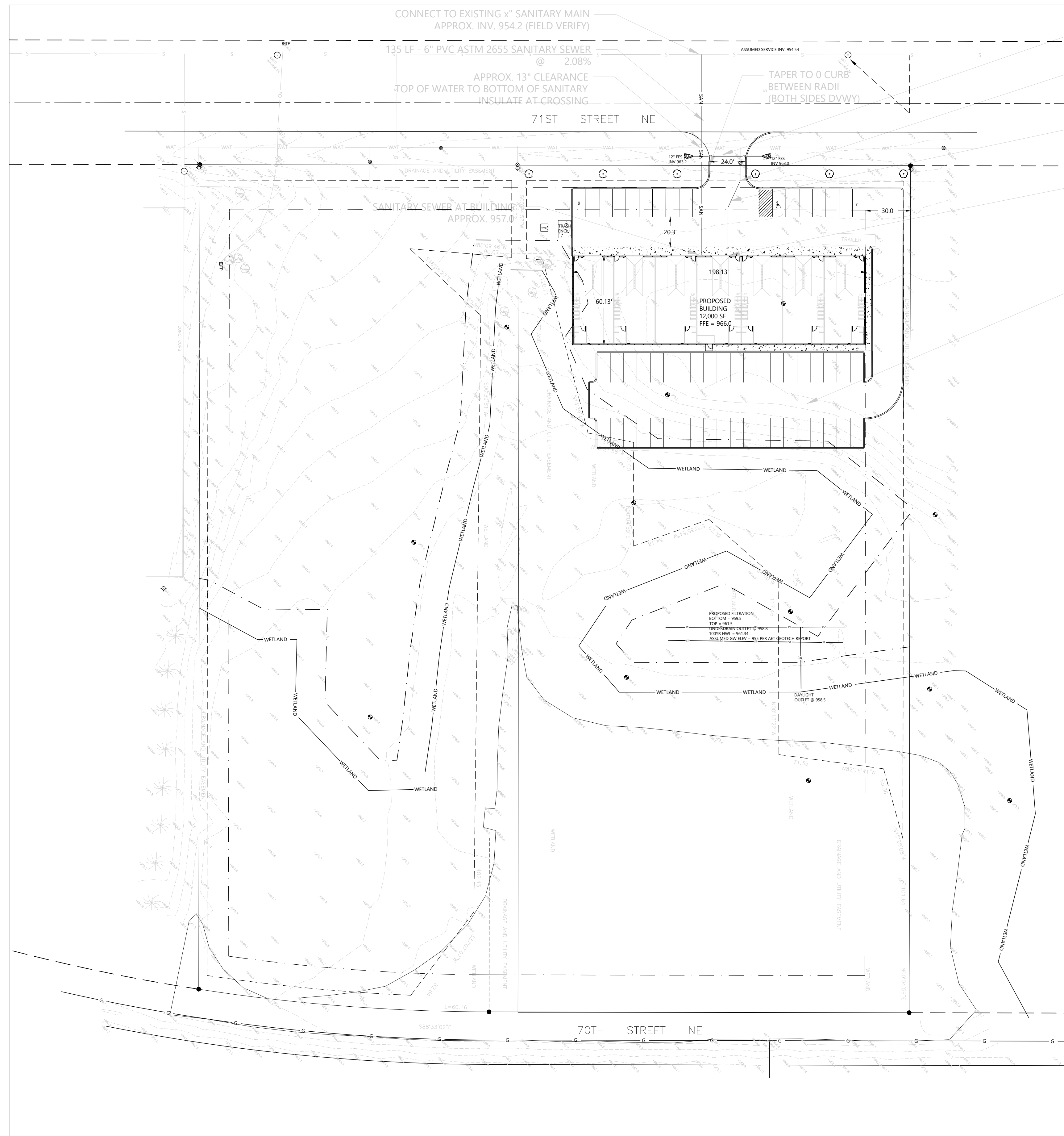

I HEREBY CERTIFY THAT THIS PLAN, SPECIFICATION, OR REPORT WAS PREPARED BY ME OR UNDER MY DIRECT SUPERVISION AND THAT I AM A DULY LICENSED PROFESSIONAL ENGINEER UNDER THE LAWS OF THE STATE OF MINNESOTA.

Krystle L. Bloch
 KRISTLE L. BLOCH
 7-16-2025 DATE
 49893 LIC. NO.

ACUITY HOLDINGS
 OTSEGO DEVELOPMENT
 OTSEGO, MN
 SITE AND UTILITY PLAN

REVISIONS	NO.	DATE	BY	DESCRIPTION
	1	9/17/25	KB	UTILITY UPDATES PER MDL COMMENTS
	2	9/25/25	KB	UTILITY UPDATES PER MDL COMMENTS
	3	3/9/26	KB	POND/PARKING CHANGE. ADD SWPPP

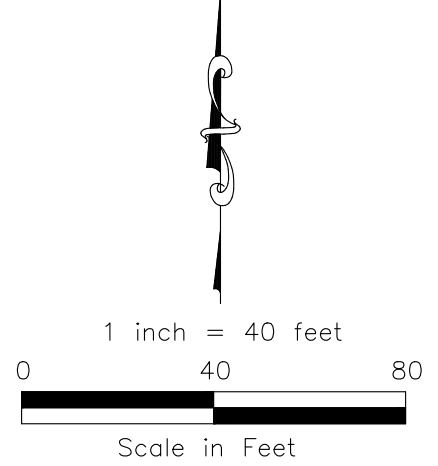

I HEREBY CERTIFY THAT THIS PLAN, SPECIFICATION, OR REPORT WAS PREPARED BY ME OR UNDER MY DIRECT SUPERVISION AND THAT I AM A DULY LICENSED PROFESSIONAL ENGINEER UNDER THE LAWS OF THE STATE OF MINNESOTA.

Krystle L. Bloch
 KRISTLE L. BLOCH
 7-16-2025 DATE
 49893 LIC. NO.

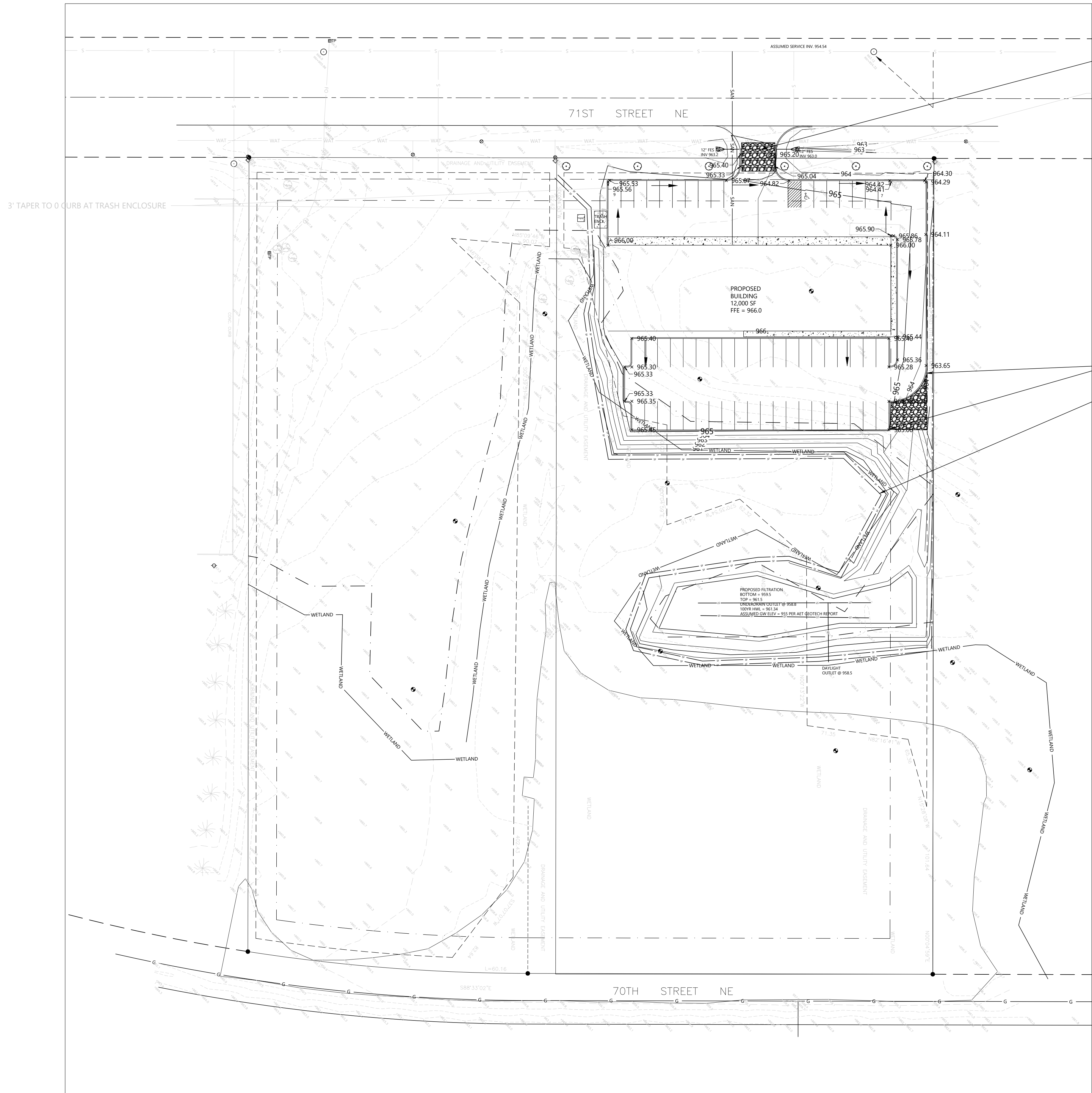

- EROSION CONTROL AND LANDSCAPING NOTES:**
1. ALL DISTURBED AREAS TO BE SEEDED AND MULCHED. 4IN MIN TOPSOIL.
 2. MULCH TYPE 1 (DISK ANCHORED) IN DISTURBED AREAS
 3. SEED MNDOT TYPE 35-221, AT A RATE OF 36.5 LB/AC
 4. ALL SLOPES STEEPER THAN 4:1, SHALL BE RESTORED WITH SEED AND PROTECTED WITH EROSION CONTROL BLANKET PER MnDOT SPEC. 3885.1 OR SODDED AND STAKED.

- SITE GRADING NOTES:**
1. THE CONTRACTOR IS SPECIFICALLY CAUTIONED THAT THE LOCATION AND/OR ELEVATION OF EXISTING UTILITIES AS SHOWN ON THESE PLANS IS BASED ON RECORDS OF THE VARIOUS UTILITY COMPANIES, AND WHERE POSSIBLE, MEASUREMENTS TAKEN IN THE FIELD. THE INFORMATION IS NOT TO BE RELIED ON AS BEING EXACT OR COMPLETE. THE CONTRACTOR SHALL VERIFY THE FIELD LOCATION OF ALL PUBLIC AND PRIVATE UTILITIES PRIOR TO CONSTRUCTION. THE CONTRACTOR SHALL CONTACT GOPHER STATE ONE CALL AT (651) 454-0002.
 2. ALL CUT OR FILL SLOPES SHALL BE 3:1 OR FLATTER UNLESS OTHERWISE NOTED.
 3. EXISTING GRADE CONTOUR INTERVALS SHOWN AT 1 FOOT INTERVALS.
 4. PROPOSED GRADE CONTOUR INTERVALS SHOWN AT 1 FOOT INTERVALS.
 5. IF ANY EXISTING STRUCTURES TO REMAIN ARE DAMAGED DURING CONSTRUCTION IT SHALL BE THE CONTRACTORS RESPONSIBILITY TO REPAIR AND/OR REPLACE THE EXISTING STRUCTURE AS NECESSARY TO RETURN IT TO EXISTING CONDITIONS OR BETTER.
 6. TOPOGRAPHIC INFORMATION TAKEN FROM A TOPOGRAPHIC SURVEY BY LAND SURVEYORS, IF CONTRACTOR DOES NOT ACCEPT EXISTING TOPOGRAPHY AS SHOWN ON THE PLANS, WITHOUT EXCEPTION, HE SHALL HAVE MADE, AT HIS EXPENSE, A TOPOGRAPHIC SURVEY BY A REGISTERED LAND SURVEYOR AND SUBMIT TO THE OWNER FOR REVIEW.
 7. CONSTRUCTION SHALL COMPLY WITH ALL APPLICABLE GOVERNING CODES AND BE CONSTRUCTED TO SAME.
 8. ALL DISTURBED AREAS WITHIN THE PUBLIC RIGHT OF WAY SHALL BE SODDED.

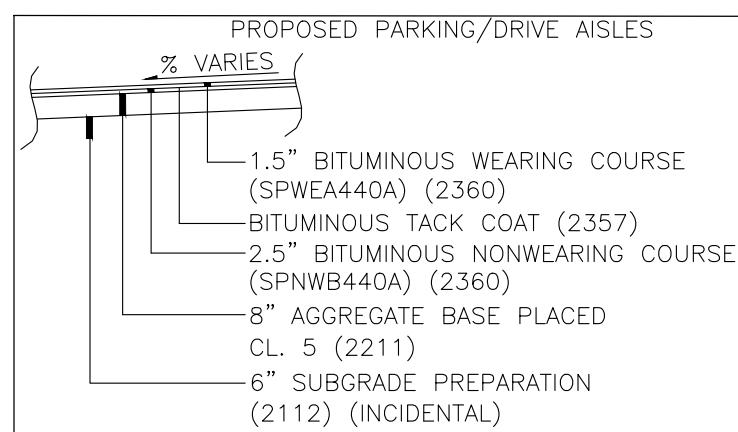

ACUITY HOLDINGS
 OTSEGO DEVELOPMENT
 OTSEGO, MN
 GRADING AND
 EROSION CONTROL PLAN

NO.	DATE	BY	DESCRIPTION
1	9/17/25	KB	UTILITY UPDATES PER MDL COMMENTS
2	9/25/25	KB	UTILITY UPDATES PER MDL COMMENTS
3	3/9/26	KB	POND/PARKING CHANGE, ADD SWPPP

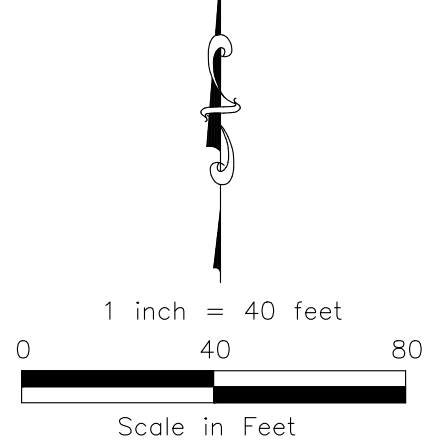

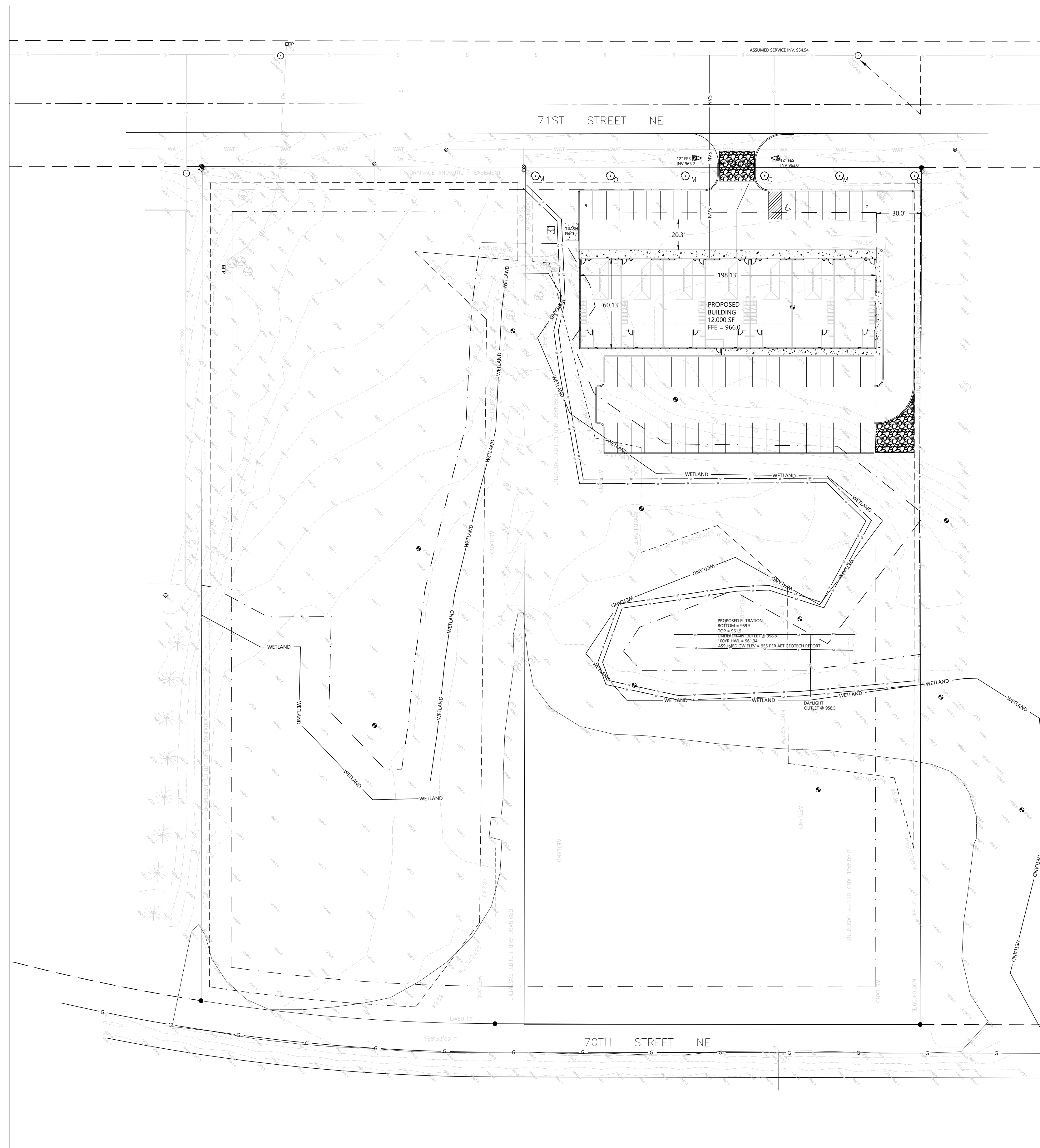

- EROSION CONTROL AND LANDSCAPING NOTES:**
1. ALL DISTURBED AREAS TO BE SEEDED AND MULCHED. 4IN MIN TOPSOIL EXCEPT AS NOTED IN NUMBER 5 BELOW.
 2. MULCH TYPE 1 (DISK ANCHORED) IN DISTURBED AREAS
 3. SEED MNDOT TYPE 35-221, AT A RATE OF 36.5 LB/AC
 4. ALL SLOPES STEEPER THAN 4:1, SHALL BE RESTORED WITH SEED AND PROTECTED WITH EROSION CONTROL BLANKET PER MNDOT SPEC. 3885.1 OR SODDED AND STAKED.
 5. NON PAVED AREAS IN FRONT OF BUILDING SHALL BE SOD.
 6. IRRIGATION (DESIGN BY OTHERS) TO BE PROVIDED ON ALL SOD AND PLANTING AREAS PER CITY CODE 5-2-3.C.2.

MINIMUM SIZE OF PLANTINGS

	Potted/Bare Root Or Balled And Burlapped
Evergreen trees (evergreen or deciduous)	3 feet to 4 feet high
Low shrubs:	
Deciduous	24 inches to 30 inches
Evergreen	24 inches to 30 inches
Spreading evergreen	18 inches to 24 inches
Ornamental trees	1 1/2 inch diameter
Shade trees	2 inch diameter
Tall shrubs and hedge material (evergreen or deciduous)	3 feet to 4 feet high

PLANTING NUMBER REQUIREMENTS:

OVERSTORY/SHADE = 50 FT ON CENTER AT PERIMETER

*USED ONLY FRONT PERIMETER, AS WEST AND SOUTH IS WETLAND AND PROPOSED POND. EAST SIDE HAS SWALE, AND SHALL NOT HAVE TREES TO IMPEDE FLOW TO POND.

TREE PROTECTION

TO BE PROVIDED BY SILT FENCE. SEE EROSION CONTROL PLAN

TREE PLANTING NOTES

1. TREE LOCATION SUBJECT TO CHANGE TO AVOID UTILITY CONFLICT.

- ⊙M RED MAPLE/ACER (3)
- ⊙O WHITE OAK/QUERCUS ALBA (3)

JOB NO. 25-02

I HEREBY CERTIFY THAT THIS PLAN, SPECIFICATION, OR REPORT WAS PREPARED BY ME OR UNDER MY DIRECT SUPERVISION AND THAT I AM A DULY LICENSED PROFESSIONAL ENGINEER UNDER THE LAWS OF THE STATE OF MINNESOTA.

KRISTLE L. BLOCH
 7-16-2025
 49893
 LIC. NO.
 DATE

ACUITY HOLDINGS
 OTSEGO DEVELOPMENT
 OTSEGO, MN
 LANDSCAPING PLAN

REVISIONS	NO.	DATE	BY	DESCRIPTION
	1	9/17/25	KB	UTILITY UPDATES PER MDL COMMENTS
	2	9/25/25	KB	UTILITY UPDATES PER MDL COMMENTS
	3	3/9/26	KB	POND/PARKING CHANGE. ADD SWPPP

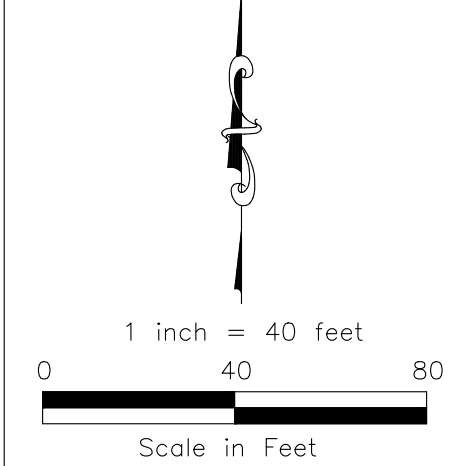

May 31, 2022 - 8:33am
K:\cond_app\Projects\OTSEGO_REV20.dwg EROSION\Plate-501.dwg

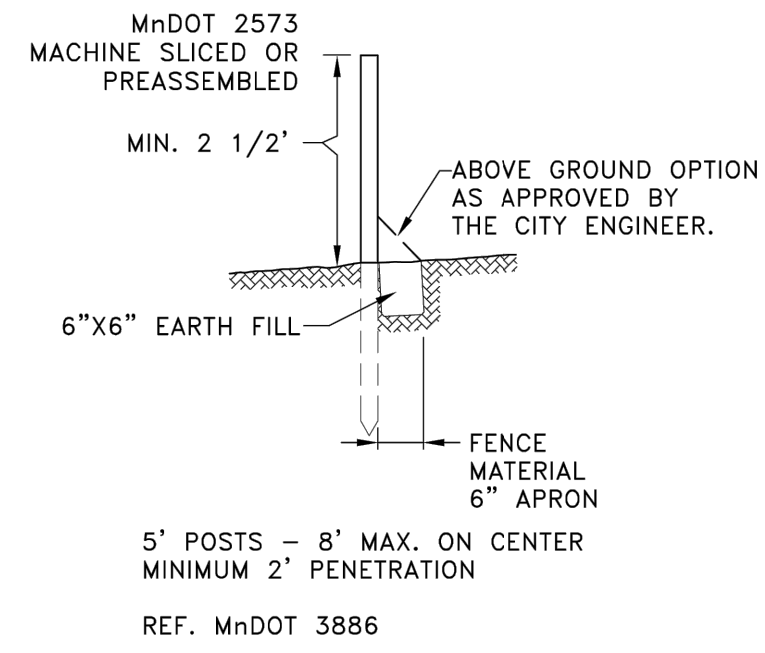

SILT FENCE
NO SCALE

APPROVED		STANDARD PLATE NO. 501
REVISED 5-10-07		

May 31, 2022 - 8:51am
K:\cond_app\Projects\OTSEGO_REV20.dwg EROSION\Plate-505.dwg

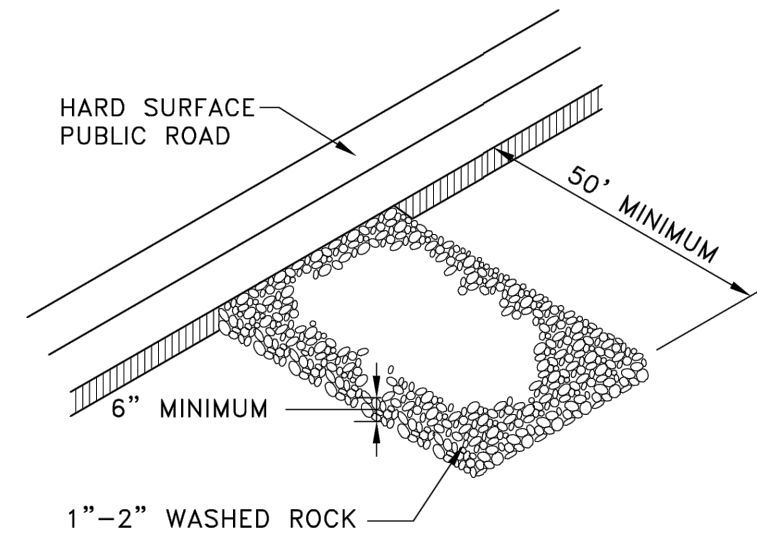

ROCK CONSTRUCTION ENTRANCE
NO SCALE

APPROVED		STANDARD PLATE NO. 505
REVISED		

May 31, 2022 - 8:07am
K:\cond_app\Projects\OTSEGO_REV20.dwg EROSION\Plate-702.dwg

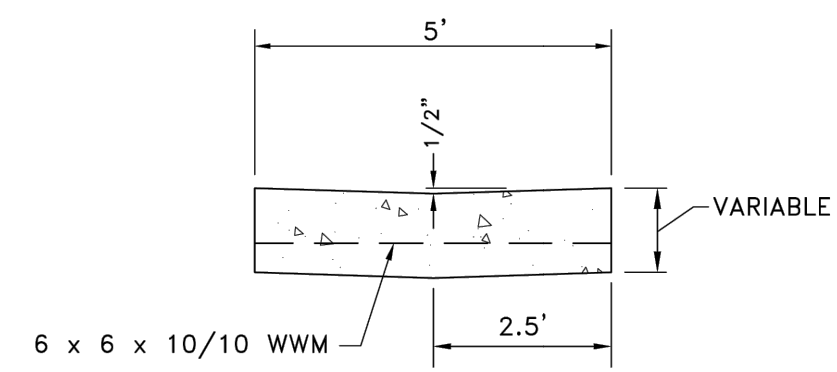

SECTION AA
NOTE: DEPTH OF CONCRETE SHALL BE DETERMINED BY TYPE OF CURB AND GUTTER

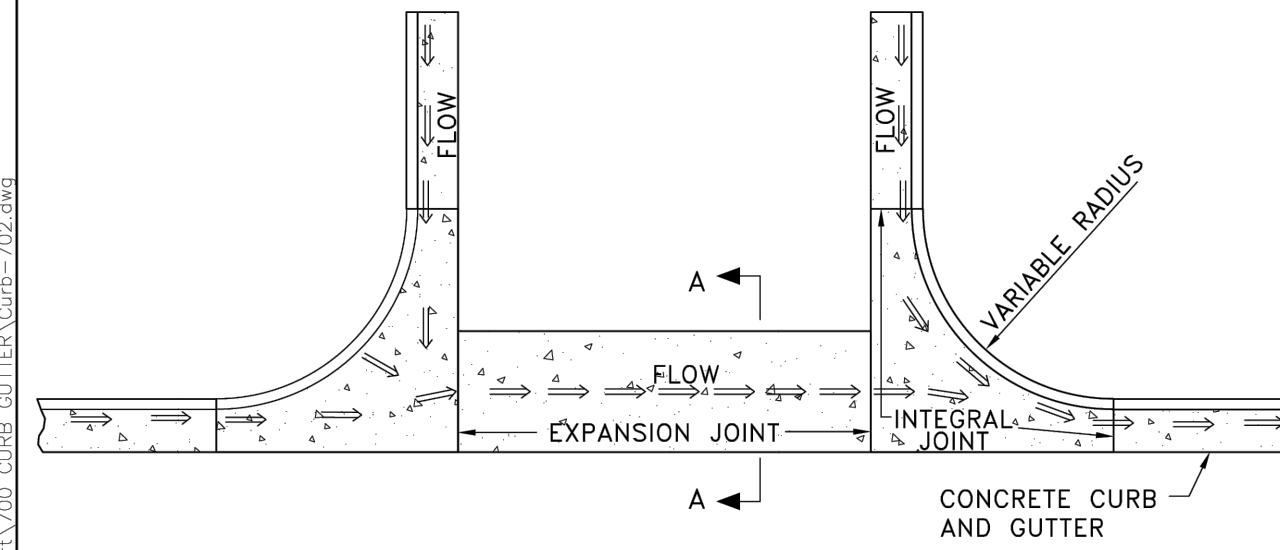

TYPICAL CROSS GUTTER
NO SCALE

APPROVED		STANDARD PLATE NO. 702
REVISED JANUARY 2007		

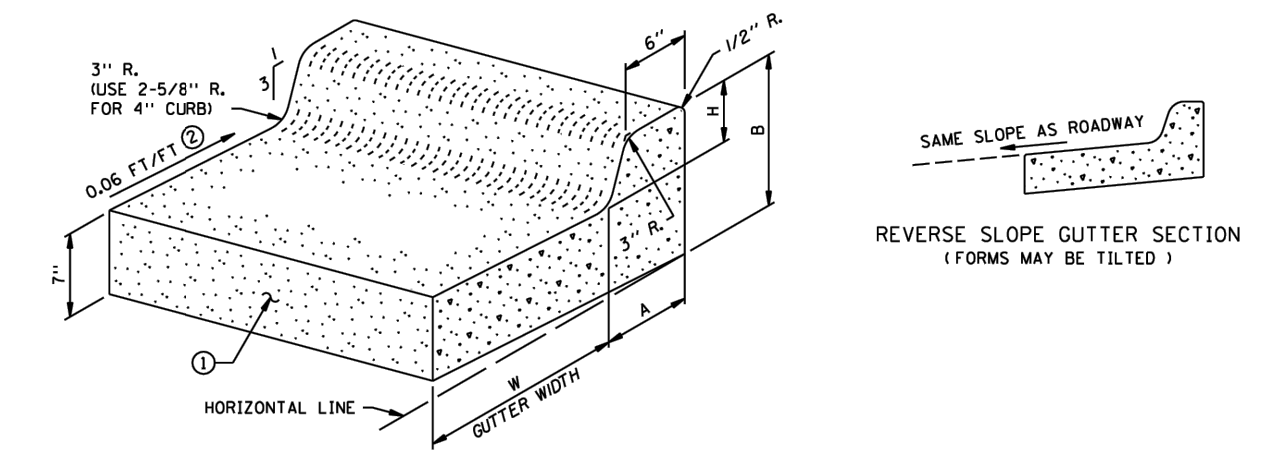

DESIGN B

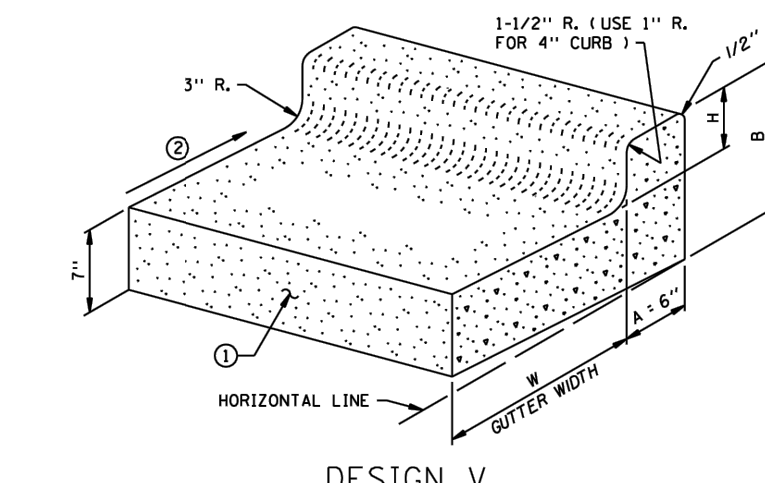

DESIGN V

NOTES:
① LONGITUDINAL JOINT WHEN ADJACENT TO RIGID PAVEMENT OR BASE. SEE STANDARD PLANS MANUAL FOR JOINT INFORMATION.
② SLOPE 0.06 FT/FT NORMAL, UNLESS OTHERWISE SPECIFIED. IF A DIFFERENT GUTTER SLOPE IS PERMITTED, THE FORM MAY BE TILTED.

DESIGN	W = 12"				W = 18"				W = 24"				W = 30"				W = 36"					
	H	A	B	CONCRETE	H	A	B	CONCRETE	H	A	B	CONCRETE	H	A	B	CONCRETE	H	A	B	CONCRETE		
DESIGN B	4	7-3/8"	11-1/2"	B412	0.0421	23.8	B418	0.0529	18.9	B424	0.0637	15.1	B430	0.0745	13.4	B436	0.0853	11.7				
	6	8"	13-1/2"	B612	0.0474	21.1	B618	0.0582	17.2	B624	0.0690	14.5	B630	0.0798	12.5	B636	0.0906	11.0				
	8	8-5/8"	15-1/2"	B812	0.0529	18.9	B818	0.0637	15.1	B824	0.0745	13.4	B830	0.0853	11.7	B836	0.0962	10.4				
	9	9"	16-5/8"	B912	0.0559	17.9	B918	0.0667	15.0	B924	0.0775	12.9	B930	0.0883	11.3	B936	0.0991	10.1				
	10	9-3/8"	17-3/8"	B1012	0.0589	17.0	B1018	0.0697	14.4	B1024	0.0805	12.4	B1030	0.0913	11.0	B1036	0.1021	9.8				
DESIGN V	4	6"	11-3/8"	V412	0.0396	25.3	V418	0.0504	19.9	V424	0.0612	16.4	V430	0.0720	13.9	V436	0.0828	12.1				
	6	6"	13-3/8"	V612	0.0426	23.5	V618	0.0534	18.7	V624	0.0642	15.6	V630	0.0750	13.4	V636	0.0858	11.7				
	8	6"	15-3/8"	V812	0.0457	21.9	V818	0.0565	17.7	V824	0.0673	14.9	V830	0.0781	12.8	V836	0.0889	11.3				
	9	6"	16-3/8"	V912	0.0472	21.2	V918	0.0580	17.2	V924	0.0688	14.5	V930	0.0796	12.6	V936	0.0904	11.1				
	10	6"	17-3/8"	V1012	0.0487	20.5	V1018	0.0595	16.8	V1024	0.0703	14.2	V1030	0.0811	12.4	V1036	0.0919	10.9				

APPROVED		STANDARD PLATE NO. 7100H
REVISED MARCH 11, 1994		

STATE OF MINNESOTA
DEPARTMENT OF TRANSPORTATION
CONCRETE CURB AND GUTTER
DESIGN B AND DESIGN V

SPECIFICATION REFERENCE: 2531
REVISION DATE: 2-28-05

BLOCH ENGINEERING
BLOCH ENGINEERING, PLLC
blochengineering.com
32210 XEON ST NW
CAMBRIDGE, MN 55008
krystle@blochengineering.com

JOB NO. 25-02

I HEREBY CERTIFY THAT THIS PLAN, SPECIFICATION, OR REPORT WAS PREPARED BY ME OR UNDER MY DIRECT SUPERVISION AND THAT I AM A DULY LICENSED PROFESSIONAL ENGINEER UNDER THE LAWS OF THE STATE OF MINNESOTA.

DATE: 7-16-2025
LIC. NO.: 49893
KRISTLE L. BLOCH

ACUITY HOLDINGS
OTSEGO DEVELOPMENT
OTSEGO, MN
STANDARD DETAILS

REVISIONS	NO.	DATE	DESCRIPTION
	1	9/17/25	KB UTILITY UPDATES PER MDL COMMENTS
	2	9/25/25	KB UTILITY UPDATES PER MDL COMMENTS
	3	3/9/26	KB POND/PARKING CHANGE, ADD SWPPP

STORM WATER POLLUTION PREVENTION PLAN (SWPPP)

PROJECT DESCRIPTION:

This proposed site plan consists of the new construction of a building and corresponding parking. This will include regrading. The total area of construction and grading will be approximately 1.2 acres.

The new building and drive/parking runoff will flow to the proposed pond to the south.

SWPPP IMPLEMENTATION

The Contractor is responsible for implementation of the SWPPP and the installation, inspection, and maintenance of the erosion prevention and sediment control BMPs before and during construction. The Contractor will have an Erosion Control Supervisor who is responsible for coordinating the erosion prevention and sediment control BMPs. Acuity is responsible for long term operation and maintenance of the permanent storm water management system.

PROJECT CONTACT IMPLEMENTATION/MAINTENANCE:

Erosion and Sediment Control, BMP Inspection Performed By:
TBD (CERTIFIED INSPECTOR)

Long Term Pond Maintenance Provided By:
Acuity

TIMING OF BMP INSTALLATION

The erosion prevention and sediment control BMPs shall be installed as necessary to minimize erosion from disturbed surfaces and capture sediment on site.

1. Erosion and sediment control BMPs must be installed prior to the start of construction.
2. Where applicable, disturbed areas will immediately be temporarily stabilized prior to permanent turf establishment whenever construction ceases for 7 days, with special consideration of areas within 200 feet continuous positive slope of a surface water.
3. Temporary or permanent energy dissipation shall be placed at pipe outlets within 24 hours after connection to a surface water.
4. Temporary stabilization of stockpiles must be initiated immediately to limit soil erosion whenever any construction activity has permanently ceased on any portion of the site and will not resume for a period exceeding 7 calendar days.
5. Planned slopes of 1:3 (V:H) or steeper and greater than 75 ft. in length will be temporarily or permanently stabilized in increments not to exceed 75 ft., prior to constructing or disturbing a new increment.
6. BMPs must remain in place until final stabilization is achieved and permit NOT has been submitted to the MPCA.
7. The normal wetted perimeter of any temporary or permanent drainage ditch or swale that drains water from any portion of the construction site, or diverts around the site, must be stabilized within 200 lineal feet from the property edge, or from the point of discharge into any surface water. Stabilization of the last 200 lineal feet must be completed within 24 hours after connecting to a surface water.
8. Developer/Contractor is responsible for removal of silt fence upon turf establishment.
9. Seeding of site shall be completed within two weeks of grading completion.

CALCULATIONS:

Total Area of Grading = 1.2 Acres
Total Existing Impervious = 0 Square Feet
Total New Impervious = 21500 Square Feet

WATER QUALITY VOLUME (TOTAL) = (1'/12") (21500 SF) = 1971 CF

VOLUME PROVIDED AT OUTLET = 10,663 CF

SOIL TYPES:

Majority C Soils

EROSION CONTROL QUANTITIES:

EROSION CONTROL QUANTITIES		
	UNIT	QUANTITY
SILT FENCE	LF	2085
TEMP. CONSTRUCTION EXIT	EACH	1

CONSTRUCTION SEQUENCE:

Construction to begin spring 2026. Silt fence around where specified and Rock entrances to be installed before any of the following scheduled events take place. Existing structures shall also be protected from sediment from the start of construction.

1. Grading
2. Parking prep and construction
3. Pond Grading

Construction completion expected Fall 2026. All temporary erosion control measures will be removed and disposed of according to MPCA requirements. Final stabilization will be established.

If construction is not completed before winter, stockpiles and any slopes must be stabilized with appropriate BMPs (mulch, seed, erosion control blanket) as applicable to avoid erosion in the following spring season.

See NPDES CWS Permit Part 11 for inspection frequency adjustments throughout the course of scheduled construction.

IMPAIRED AND SPECIAL WATERS

No special or impaired waters within 1 mile of this site.

KARST AREA PROTECTION:

There is no active Karst in this site.

CALCAREOUS FENS:

No calcareous Fen sites exist on this project.

MITIGATION DUE TO REVIEWS:

There are no stormwater mitigation measures proposed as part of environmental, endangered species, archaeological or other required local, state or federal reviews conducted for the project.

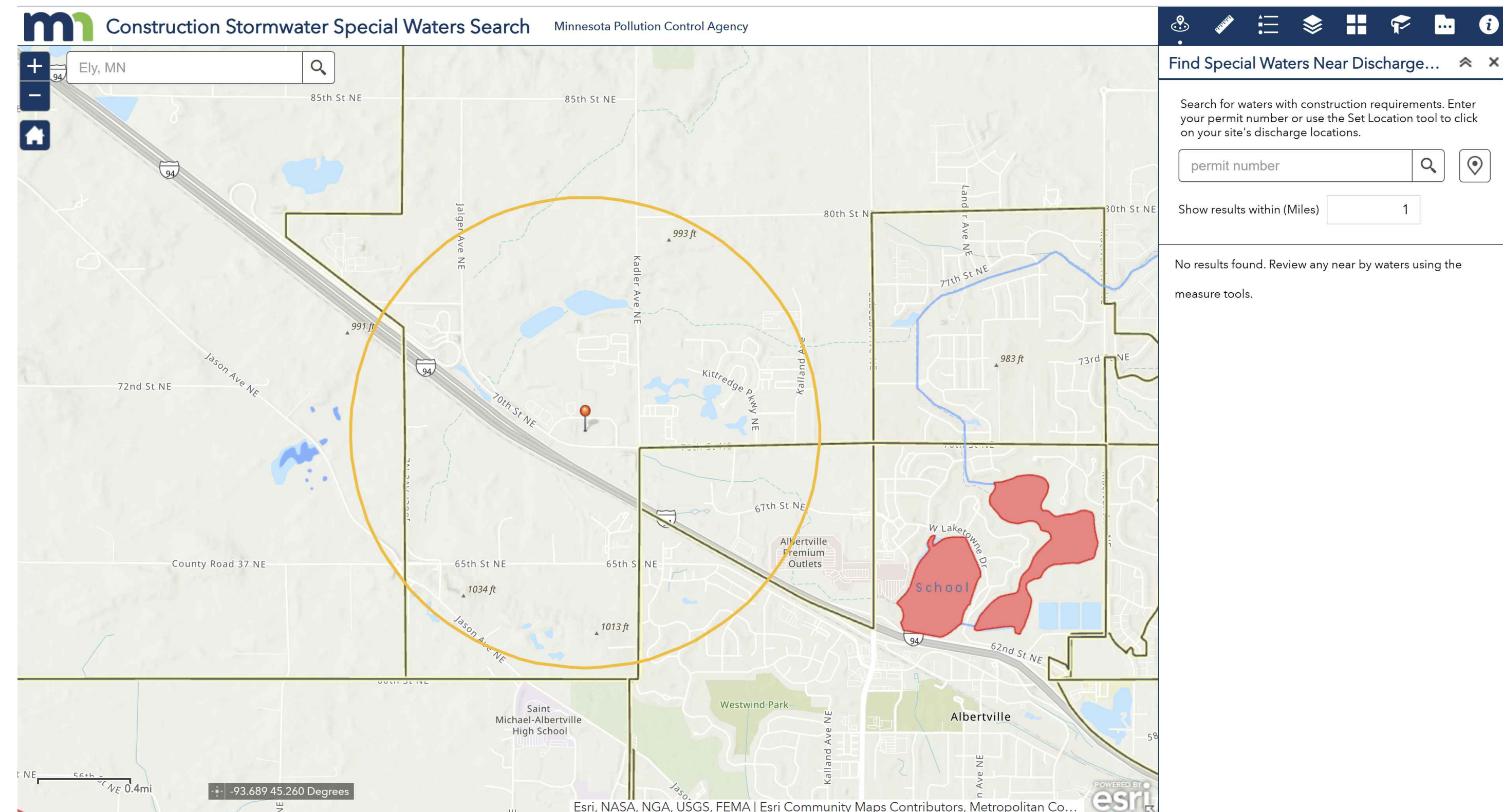

REVISIONS	
NO.	DESCRIPTION
1	9/17/25 KB UTILITY UPDATES PER MDL COMMENTS
2	9/25/25 KB UTILITY UPDATES PER MDL COMMENTS
3	3/9/26 KB POND/PARKING CHANGE. ADD SWPPP

STORM WATER POLLUTION PREVENTION PLAN (SWPPP)

CONSTRUCTION NOTES:

Construction shall be in accordance with the MPCA NPDES General Stormwater Permit for construction activity, plans, Mn/DOT Spec. Book, Standard Specifications for Construction and the special provisions. The Contractor shall maintain a stockpile of erosion control devices at all times for immediate usage. The Contractor shall keep the inspection and maintenance log. See permit Part 20 for SWPPP record retention requirements. SWPPP must be kept on site during construction by permittee who has operational control of that portion of the site. In the event of accidental sediment or pollutant discharge, the City, MPCA local contact and/or State Duty Officer shall be notified. The MPCA State Duty Officer can be reached at (800) 422-0798.

TRAINING REQUIREMENTS:

1. The Permittee(s) shall ensure the individuals identified in this part have been trained in accordance with the NPDES CSW Permit's training requirements. The Permittee(s) shall ensure the training is recorded in or with the SWPPP before the start of construction or as soon as the personnel for the project have been determined.
 - a. Who must be trained:
 - i. Individual(s) preparing the SWPPP for the project.
 - ii. Individual(s) overseeing implementation of, revising, and amending the SWPPP and individual(s) performing inspections. One of these individual(s) must be available for an on site inspection within 72 hours upon request by the MPCA.
 - iii. Individual(s) performing or supervising the installation, maintenance, and repair of BMPs. At least one individual on a project must be trained in these job duties.
 - b. Training content. The content and extent of training must be commensurate with the individual's job duties and responsibilities with regard to activities covered under this permit for the project. At least one individual present on the permitted project site (or available to the project site in 72 hours) must be trained in the job duties described in Permit Part 20.
 - c. Training documentation:
 - i. Documentation must be recorded with the SWPPP prior to the start of construction.
 - ii. Names of the personnel associated with this project that are required to be trained per Part III.F of this permit.
 - iii. Dates of training and name of instructor(s) and entity providing training.
 - iv. Content of training course or workshop (including number of hours of training).
 - d. The Permittee(s) shall ensure that the individuals are trained by local, state, federal agencies, professional organizations, or other entities with expertise in erosion prevention, sediment control or permanent stormwater management such as the University of Minnesota, Minnesota Erosion Control Association, Soil and Water Conservation Districts or the MPCA.

EROSION PREVENTION MEASURES:

1. Temporary or permanent stabilization of exposed soils, including stockpiles, shall be initiated immediately to limit soil erosion whenever any construction activity has temporarily or permanently ceased on that portion of the site and will not resume for a period exceeding 7 calendar days. (Permit Part 8.4 and 23.9).
2. The normal wetted perimeter of any temporary or permanent drainage ditch or swale that drains water for any portion of the construction site, within 200 lineal feet, must be completed within 24 hours after connecting to a surface water or property edge. Mulch, hydromulch, tackifier, polyacrylamide, or similar practice is not acceptable stabilization in any part of a drainage ditch or swale with continuous slop greater than 2%. (Permit Part 8.6-8.8).
3. Use check dams along length of conveyance channels. (Permit Part 8.7).
4. Temporary or permanent energy dissipation devices must be installed at pipe outlets within 24 hours after connection to a surface water.
5. Temporary or permanent ditches or swales that are being used as a sediment containment system during construction must be stabilized within 24 hours after no longer being used as a sediment containment system.

SEDIMENT CONTROL MEASURES:

1. In order to maintain sheet flow and minimize rills and/or gullies, there shall be no unbroken slope length of greater than 75 feet for slopes with a grade of 1:3 or steeper.
2. Sediment control practices must be established on all down gradient perimeters and upgradient of any buffer zones. These practices shall remain in place until final stabilization has been achieved and the Permit NOT form has been submitted to the MPCA.
3. Temporary soil stockpiles must have silt fence or other effective sediment controls, and cannot be placed in surface waters, including stormwater conveyances such as curb and gutter systems, or conduits and ditches unless there is a bypass in place for the stormwater.
4. Vehicle tracking of sediment from the construction site (or onto streets within the site) must be minimized by Best Management Practices (BMPs) such as stone pads, concrete or steel wash racks, or equivalent systems. Tracked sediment onto paved surfaces must be removed daily, at minimum.
5. Per Part 9.3, if down gradient sediment controls are overloaded, additional upgradient sediment control practices or redundant BMPs to eliminate overloading must be installed, and the SWPPP must be amended.
6. See permit 9.6 and Part 11 for instructions on re-installation of sediment control practices after they've been adjusted.
7. See permit Part 9.7 and 9.8 for instructions on the removal of storm drain inlet protection BMPs.
8. Direct discharges from BMPs to vegetated areas, unless infeasible.

DEWATERING AND BASIN DRAINING:

1. If dewatering is required on the site, there must be a plan in place to prevent nuisance conditions, erosion and inundation of wetlands.
2. If using filters with backwash water, backwash water must be hauled away for disposal, returned to the beginning of the treatment process, or incorporated into the site in a manner that does not erode into runoff.

THE DESCRIPTION OF INSPECTIONS AND MAINTENANCE:

1. The Permittee(s) (either the owner or operator, whoever is identified in the SWPPP) must routinely inspect the entire construction site at least once every seven (7) days during active construction and within 24 hours after a rainfall event greater than 0.5 inches in 24 hours.

INSPECTION AND MAINTENANCE REQUIREMENTS MUST INCLUDE:

- Date and time of inspections. All inspections and maintenance conducted during construction shall be recorded within 24 hours in writing and these records must be retained in the SWPPP
- Name of person(s) conducting inspections.
- Findings of inspections, including specific locations where there are recommendations for corrective actions.
- Corrective actions taken (including dates, times, and party completing maintenance activities).
- Date and amount of all rainfall events greater than 1/2 inch (0.5 inches) in 24 hours. Rainfall amounts must be obtained by a properly maintained rain gauge onsite, a weather station within 1 mile of the project location, or a weather reporting system that provides site specific rainfall data from radar summaries.
- See permit Part 6.1-6.4 for amendments to SWPPP.
- Construction site vehicle exit locations must be inspected for evidence of off-site sediment tracking onto paved surfaces. Tracked sediment must be removed from all paved surfaces within 24 hours of discovery (NPDES CSW Permit Part 9.12).
- Infiltration and Bioretention facility must be inspected for sedimentation.
- Discharges discovered during inspections shall be documented per NPDES CSW Permit part 11.11.f

MAINTENANCE PERFORMANCE:

1. All nonfunctional BMPs must be repaired, replaced, or supplemented with functional BMPs by the end of the next business day after discovery, or as soon as field conditions allow access unless another time frame is specified that is not less restrictive than permit requirements. See permit Part 11.4 for specific requirements.
2. Perimeter control devices must be repaired, replaced, or supplemented when nonfunctional or sediment reaches on-half the height of the device.
3. Temporary and permanent sediment basins must be drained and sediment removed when the depth of sediment collected reaches on-half storage volume
4. All sediment deposits and deltas must be removed from surface waters (including drainage ways, catch basins, and other drainage systems) and the removal areas restabilized within 7 days.
5. Permanent stormwater treatment BMPs must be inspected and maintained per NPDES CSW Permit 11.3

POLLUTION PREVENTION MANAGEMENT:

1. Solid Waste: Sediment, asphalt and concrete millings, floating debris, paper, plastic, fabric, construction and demolition debris and other wastes must be properly collected, stored, and disposed of in accordance with Minn. R.ch.7035. This includes any materials used for erosion control.
2. Hazardous and Toxic Materials: Includes, but is not limited to: Oil, gasoline, paint and any hazardous substances must be properly stored, including secondary containment, to prevent spills, leaks or other discharge. Restricted access to storage areas must be provided to prevent vandalism. Storage and disposal of hazardous waste must be in accordance with Minn.R.Ch.7045
3. External washing of trucks and other construction vehicles must be limited to a defined area of the site. Runoff must be contained and waste properly disposed of.
4. No engine degreasing is allowed on site.
5. Concrete washout onsite: All liquid and solid wastes generated by concrete washout operations must be contained in a leak-proof containment facility or impermeable liner. A compacted clay liner that does not allow washout liquids to enter ground water is considered an impermeable liner. The liquid and solid wastes must not contact the ground, and there must not be runoff from the concrete washout operations or areas. Liquid and solid wastes must be disposed of properly and in compliance with MPCA regulations. A sign must be installed adjacent to each washout facility to inform concrete equipment operators to utilize the proper facilities.
6. Building products that have the potential to leach pollutants must be under cover. (NPDES CSW Permit Part 12.2)
7. Pesticides, herbicides, insecticides, fertilizers, treatment chemicals, and landscaped materials must be under cover. (NPDES Permit Part 12.3).
8. Portable toilets must be positioned so that they are secure and will no be tipped or knocked over. Sanitary waste must be disposed of properly in accordance with Minn.R.ch.7041. (NPDES CSW Permit Part 12.6)
9. Spill Prevention and Response Requirements: Adequate supplies must be available at all times to clean up discharged materials and an appropriate method must be available for recovered spilled materials. Spills must be reported and cleaned up immediately as required by Minn. Stat. 115.061 using dry cleanup measures where possible.

FINAL STABILIZATION:

1. Permanent stabilization of exposed soils, including stockpiles, shall be initiated immediately to limit soil erosion whenever any construction activity has permanently ceased on any portion of the site and will not resume for a period exceeding 7 calendar days.
2. The permanent stormwater treatment system must be constructed, meet all requirements, and operating as designed.
3. All sediment must be removed from permanent stormwater management system and conveyance systems.
4. All temporary synthetic erosion prevention and and sediment control BMPs must be removed.
5. See Landscape sheets for turf establishment.
6. Final stabilization is achieved by a uniform perennial vegetative cover with a density of 70% of expected growth over the entire pervious area.

DISCHARGE TO WETLANDS:

2. If there is a wetland impact caused by filling, draining, excavation or inundation, how has that impact been addressed by permits or other approvals from an official statewide program (U.S. Army Corps of Engineers 404 program, Minnesota Department of Natural Resources, or the State of Minnesota Wetland Conservation Act)? If the impact is considered exempted or non jurisdictional by theses programs, how is the impact in conformance with the sequence mitigation requirements of MPCA water quality standards in MN Rule 7050.0186 <https://www.revisor.leg.state.mn.us/rules/?id=7050.0186>

MISCELLANEOUS:

1. Conventional erosion and sediment control to be used. If necessary to use chemical treatment, permittee must follow guidelines as stated in NPDES Permit Part 9.18
2. No Site assessment for groundwater or soil contamination required.

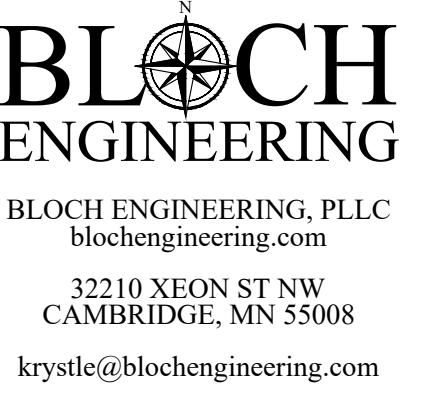

JOB NO. 25-02

I HEREBY CERTIFY THAT THIS PLAN, SPECIFICATION, OR REPORT WAS PREPARED BY ME OR UNDER MY DIRECT SUPERVISION AND THAT I AM A DULY LICENSED PROFESSIONAL ENGINEER UNDER THE LAWS OF THE STATE OF MINNESOTA.

 KRISTLE L. BLOCH
 7-16-2025 DATE
 49893 LIC. NO.

ACUITY HOLDINGS
OTSEGO DEVELOPMENT
OTSEGO, MN

SWPPP

REVISIONS	NO.	DATE	BY	DESCRIPTION
	1	9/17/25	KB	UTILITY UPDATES PER MDL COMMENTS
	2	9/25/25	KB	UTILITY UPDATES PER MDL COMMENTS
	3	3/9/26	KB	POND/PARKING CHANGE, ADD SWPPP