



Clover Park Professional Square

Clover Park Professional Square is a stately two-story, multi-tenant professional office building in the heart of Lakewood. Located within minutes of I-5, it is an easy walk to the Lakewood Towne Centre. Excellent visibility from Gravelly Lake Drive. Directory signage is located in the landscaped courtyard, and panel signage hangs overhead along the walkways. A lift at the end of the building makes it accessible. Two upper-floor suites are available in convenient configurations.

Property Overview

- Service lift for wheelchair accessibility
- Monument signage available
- Ample parking in lighted lot
- Pierce Transit stops directly in front of building
- Walking distance to Lakewood Towne Centre
- Three upper level suites available
- Suite 204B - 737 SF - Available Now
- Suite 210 - 878 SF - Available Now
- Suite 203B - 400 SF - Avail. Feb. 1, 2026
- Lease Rate: \$22.50/sf/yr
- Tenant pays separately metered power

DISCLAIMER: The above information has been secured from sources believed to be reliable, however, no representations are made to its accuracy. Prospective tenants or buyers should consult their professional advisors and conduct their own independent investigation. Properties are subject to change in price and/or availability without notice.





Retail/Office Space for Lease

LOWER FLOOR AVAILABILITY

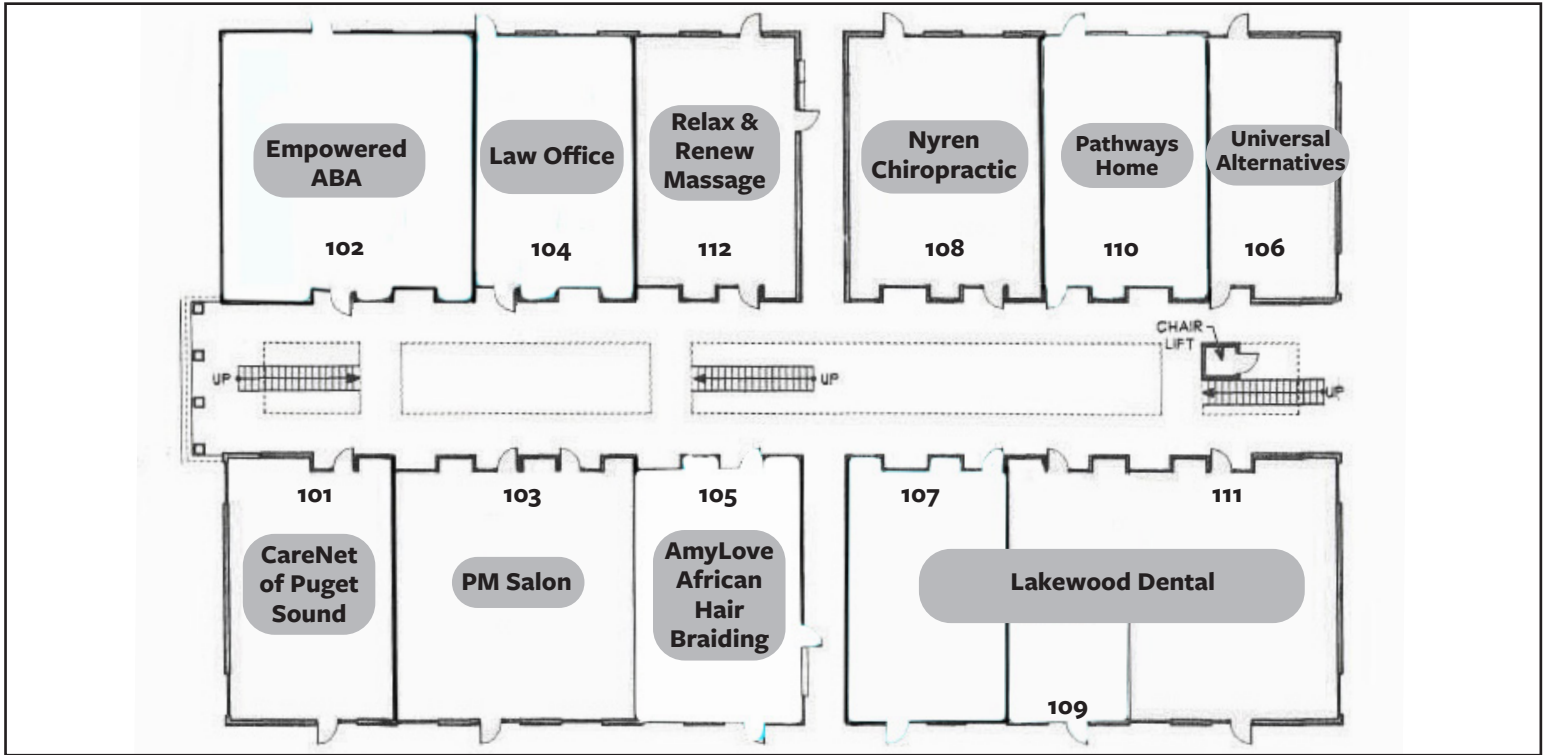

UPPER FLOOR AVAILABILITY

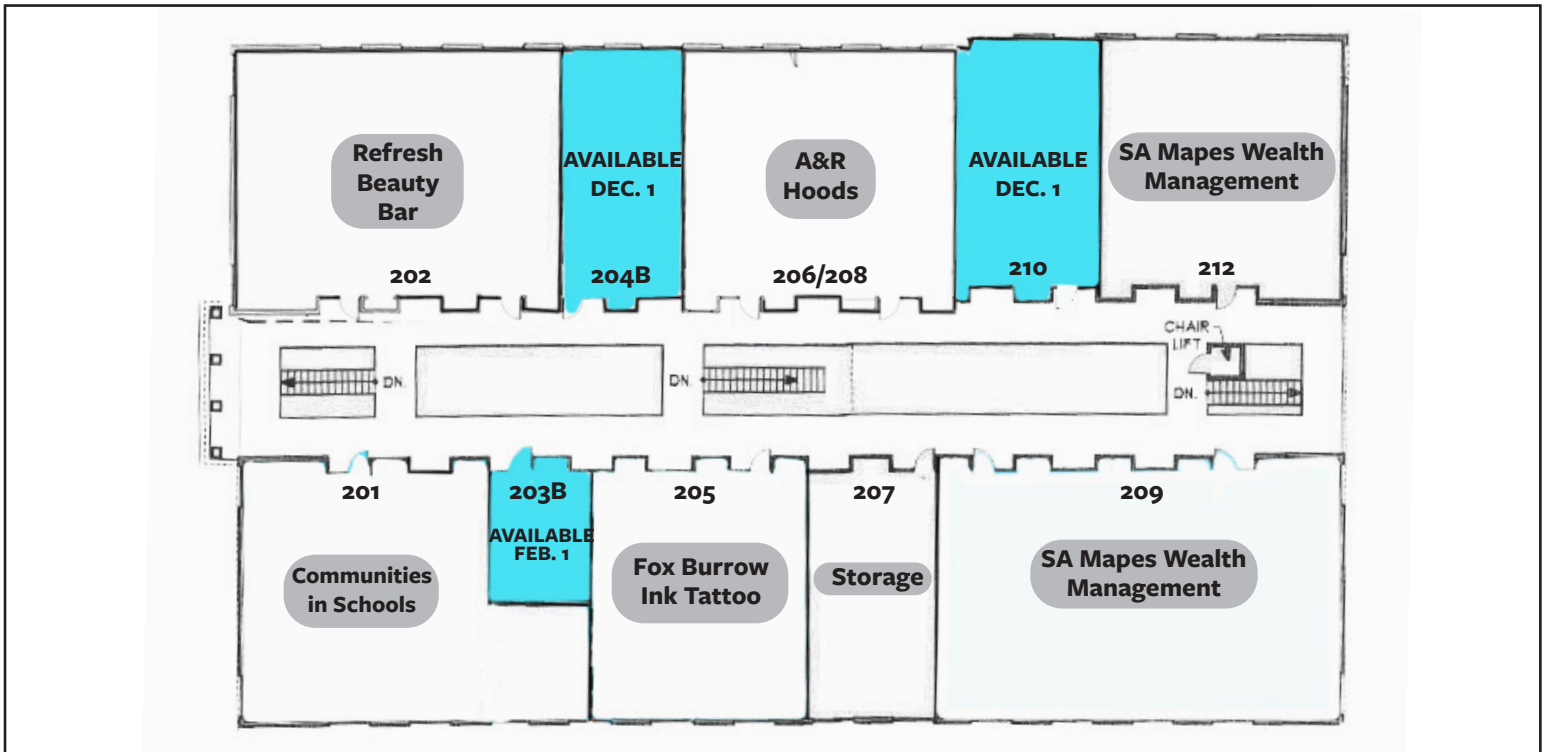



SUITE 203B - FLOOR PLAN

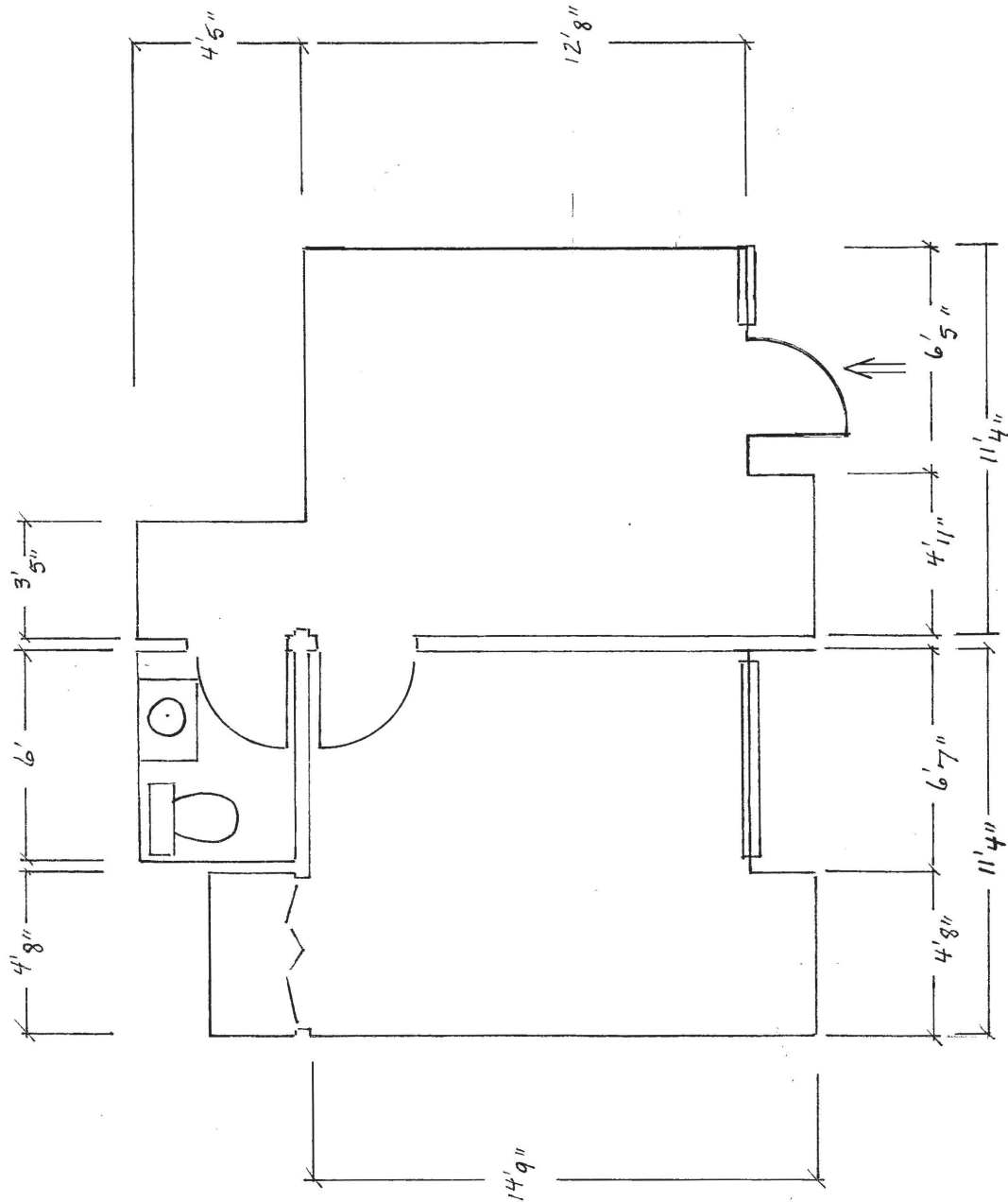



SUITE 204B - FLOOR PLAN

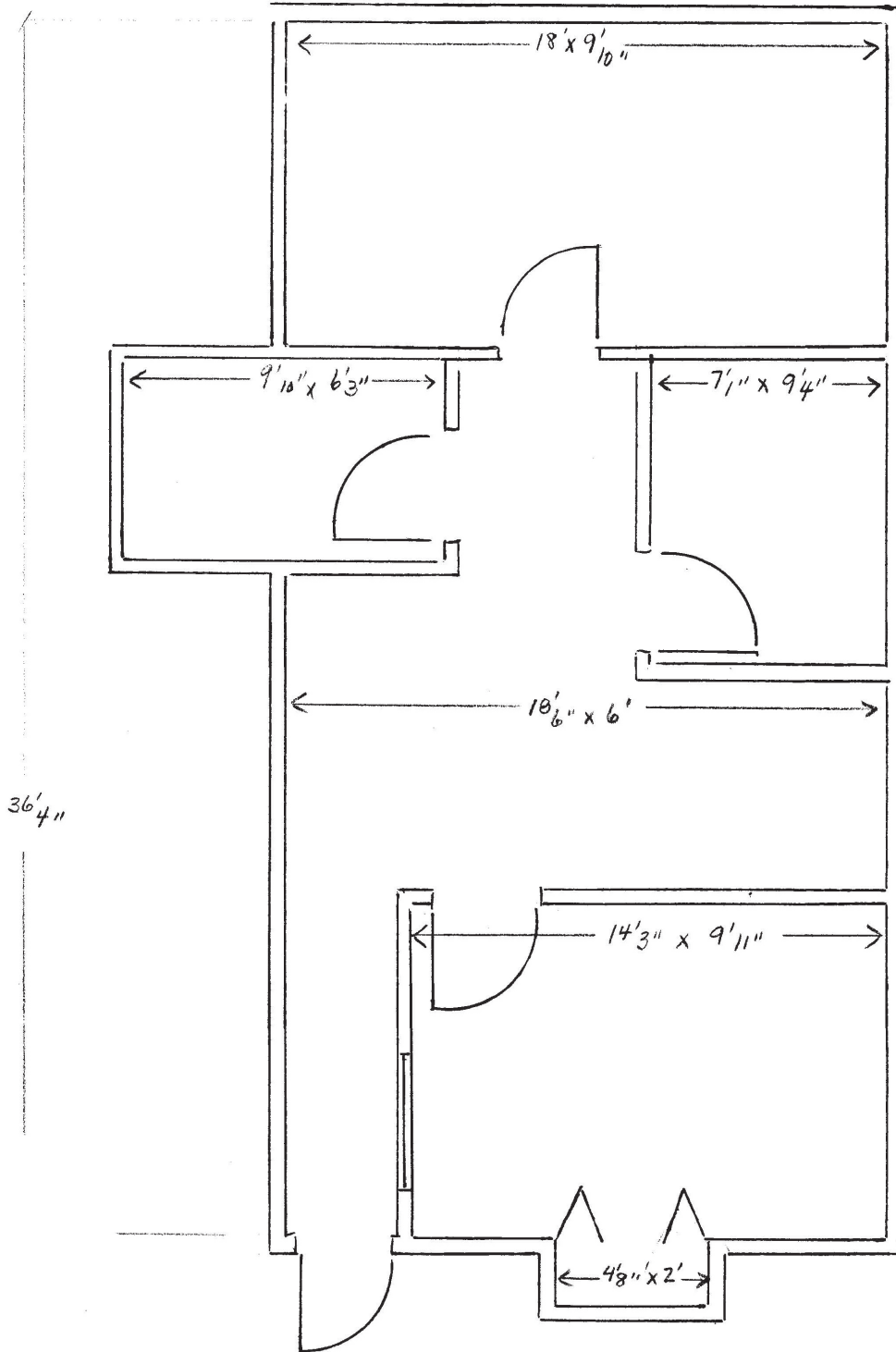



SUITE 210 - FLOOR PLAN

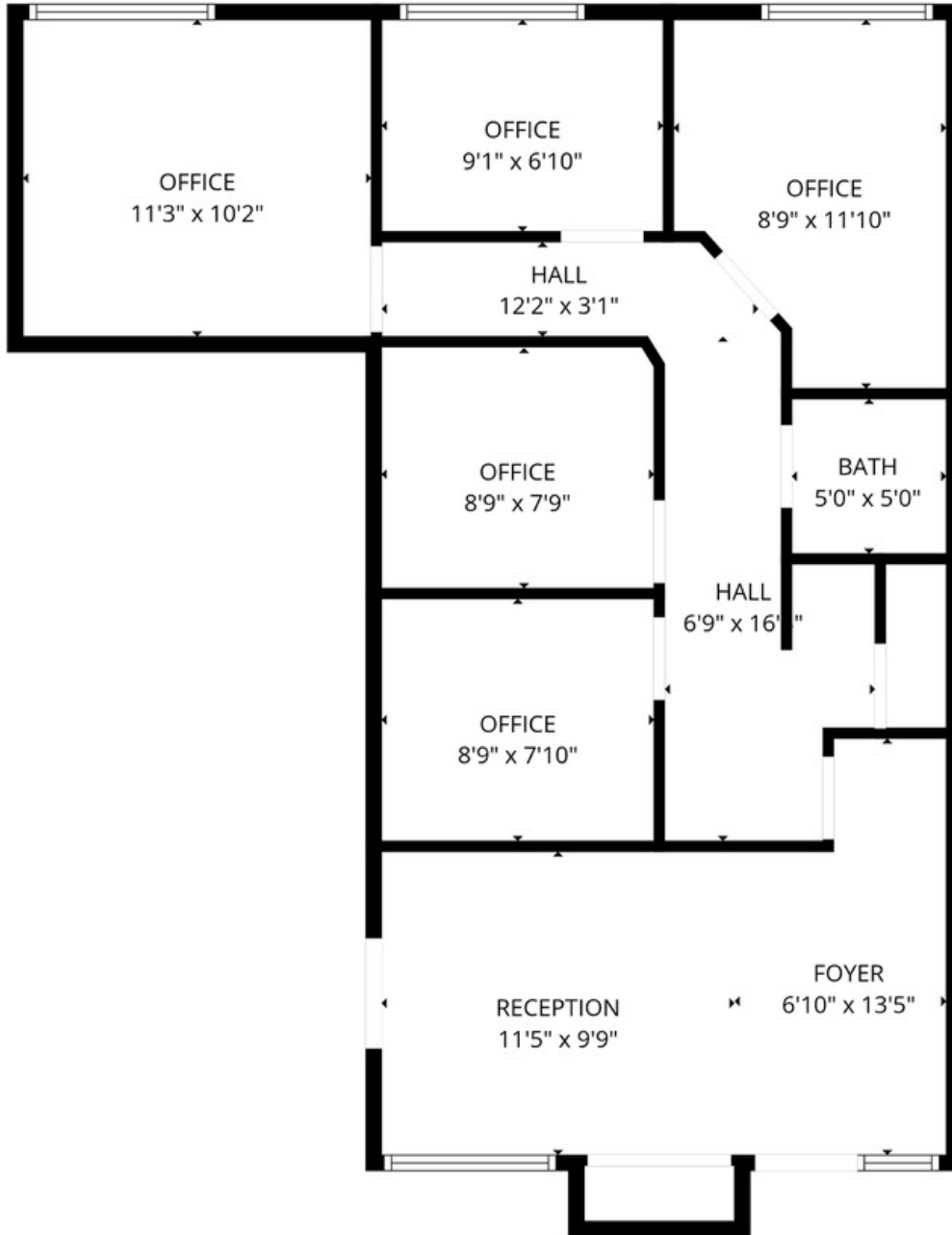

FLOOR PLAN CREATED BY CUBICASA APP. MEASUREMENTS DEEMED HIGHLY RELIABLE BUT NOT GUARANTEED.





Retail/Office Space Available

REGIONAL MAP



NEIGHBORHOOD MAP

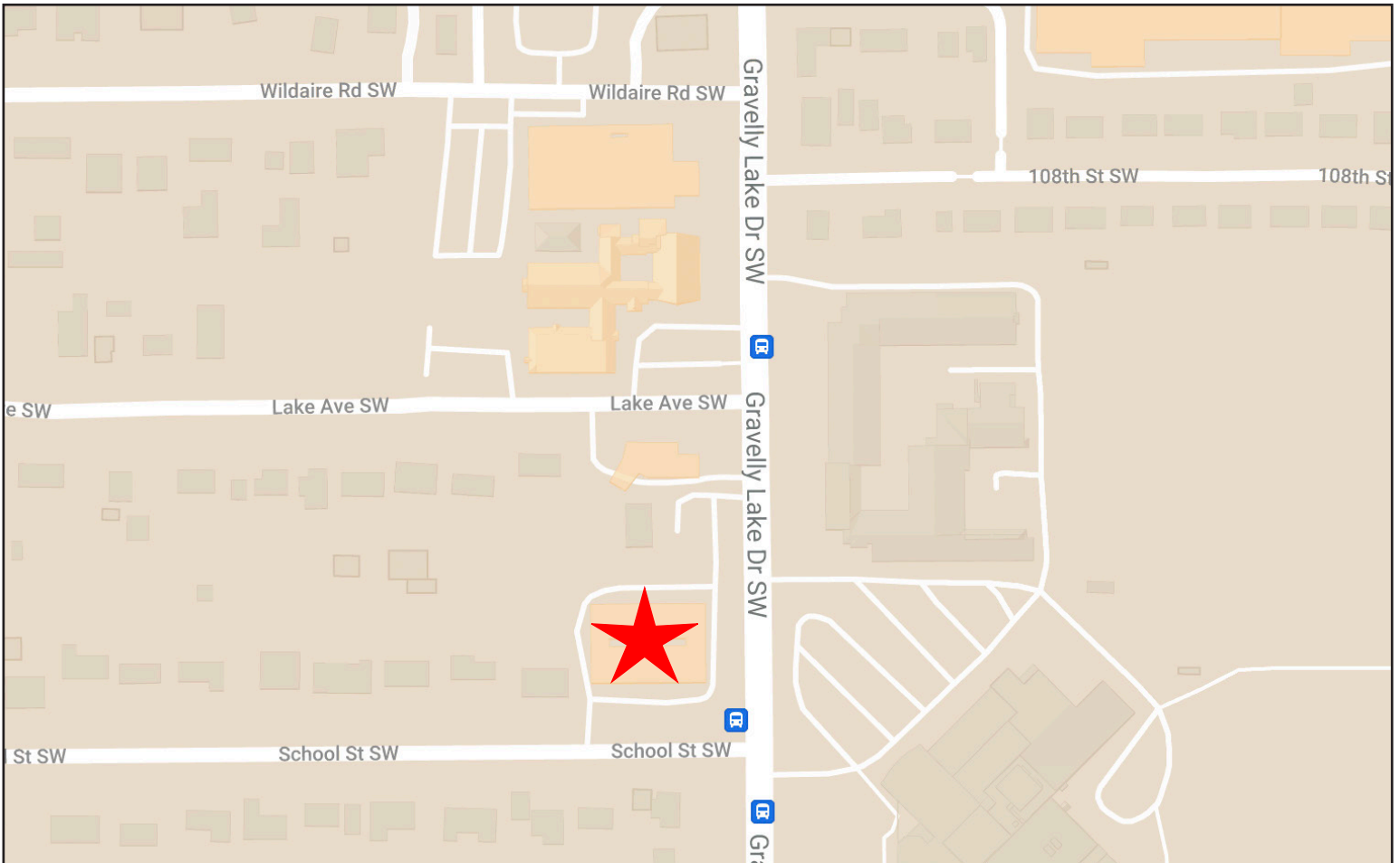

11120 Gravelly Lake Dr SW Ste 2
Lakewood, Washington 98499
johnson-commercial.com

Margot Johnson
margot@johnson-commercial.com
(253) 209-9998