

# 614 IVY

614 East Market  
Louisville, Kentucky 40202

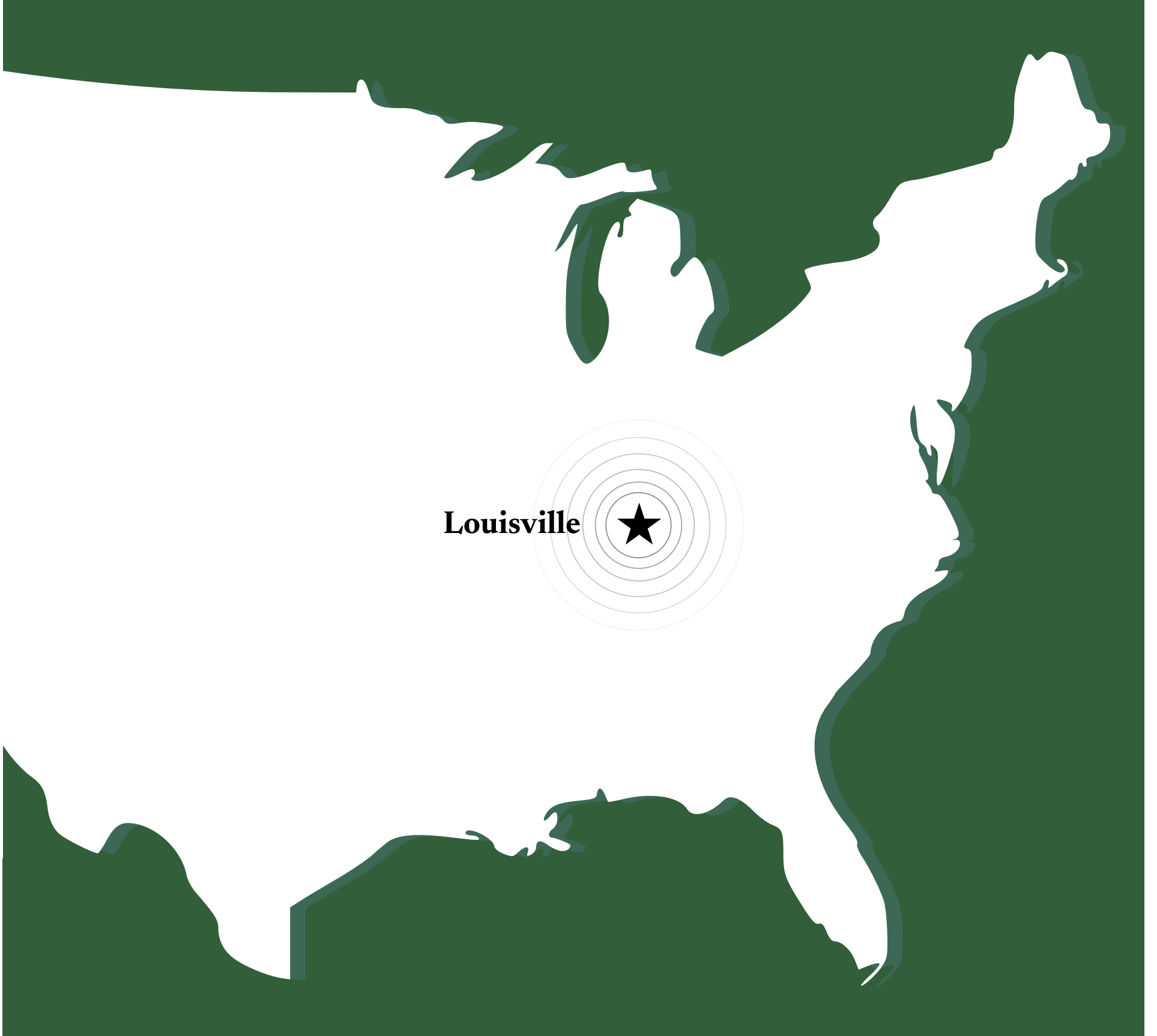



# *Louisville, Kentucky*

<p><b>#5</b> Metro For Economic Development</p>	<p><b>\$2.09B</b> New Capital Investment</p>	<p><b>60%</b> of U.S. Population Within a Day's Drive</p>
---	--	---



*NuLu is the fastest growing neighborhood between Chicago & Nashville.*



Ranked #2 Most Popular Metro for Gen-Z Home Buyers



#1 in the US for YoY Apartment Rent Growth



“Top 20 places to visit in the US”



“Top 20 Cool Streets in the US”

# Why Louisville?

From the world-renowned excitement of the Kentucky Derby at Churchill Downs to the immersive journey through the bourbon distilleries along the Urban Bourbon Trail, Louisville offers an unforgettable experience for every traveler. Indulge your senses in the city's dynamic culinary scene, explore its captivating museums and historic landmarks, and immerse yourself in the warm embrace of Southern charm. Whether you're strolling along the scenic riverfront, admiring the stunning architecture of Old Louisville, or enjoying the festive atmosphere of its lively neighborhoods, Louisville promises an authentic and memorable adventure that will leave you enchanted and eager to return.



Top 10 Culinary Scene in the



Historic Architecture



Renowned Museums and Zoos



Reliable Public Transport



World-Class Horse Racing



Legendary Bourbon Distilleries



Beautiful Public Parks



Immersive Theaters and Performances



Euphoric Music Festivals



Top-Tier Sports



Highly Educated Population



Beautiful Hotels

# Neighborhood

- 614 IVY
- Tourists & Local Attractions
- Residence/Hospitality

Nulu's walkable streets offer a variety of hospitality options for visitors and locals to enjoy



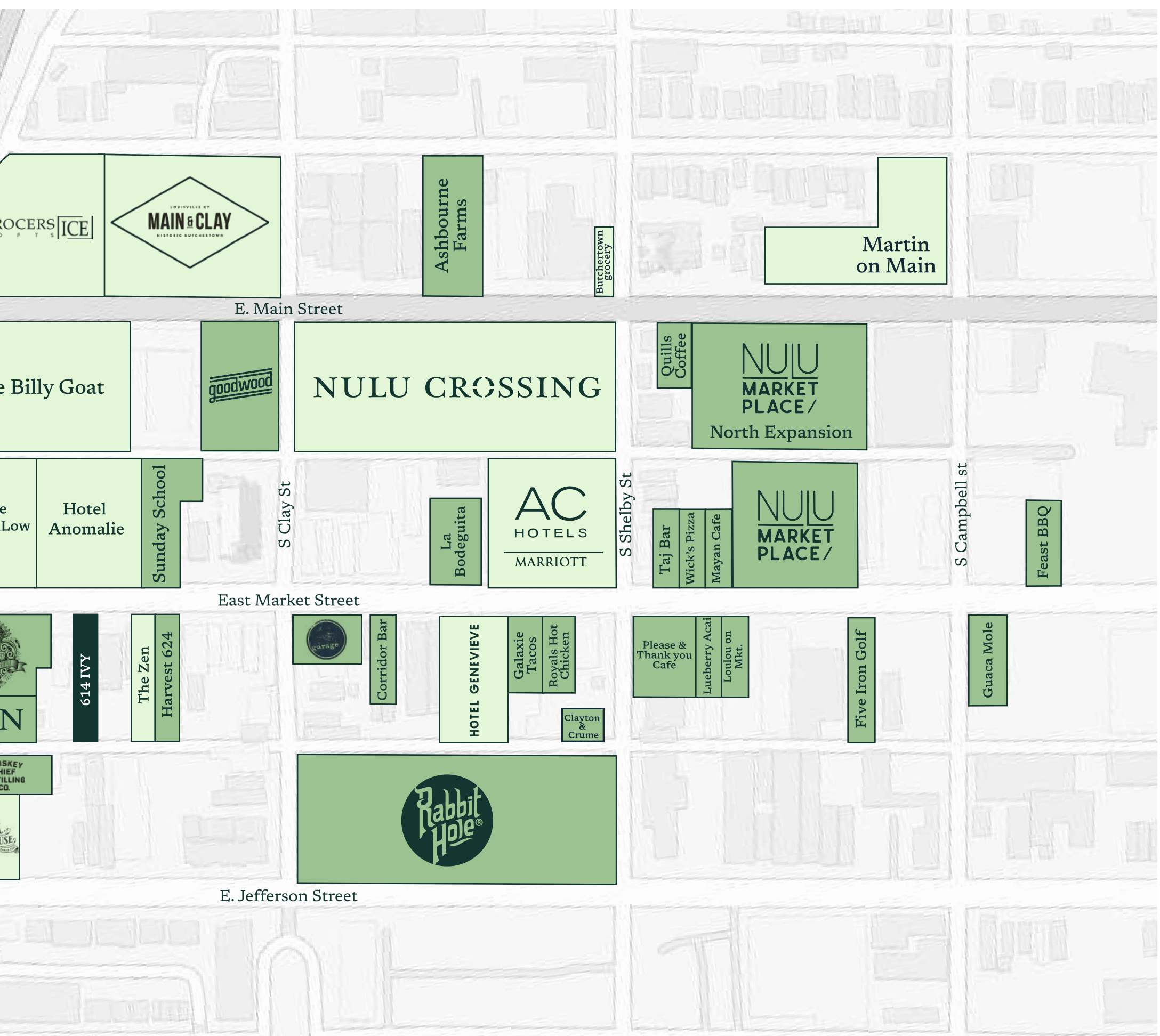

# Ground Floor Plan

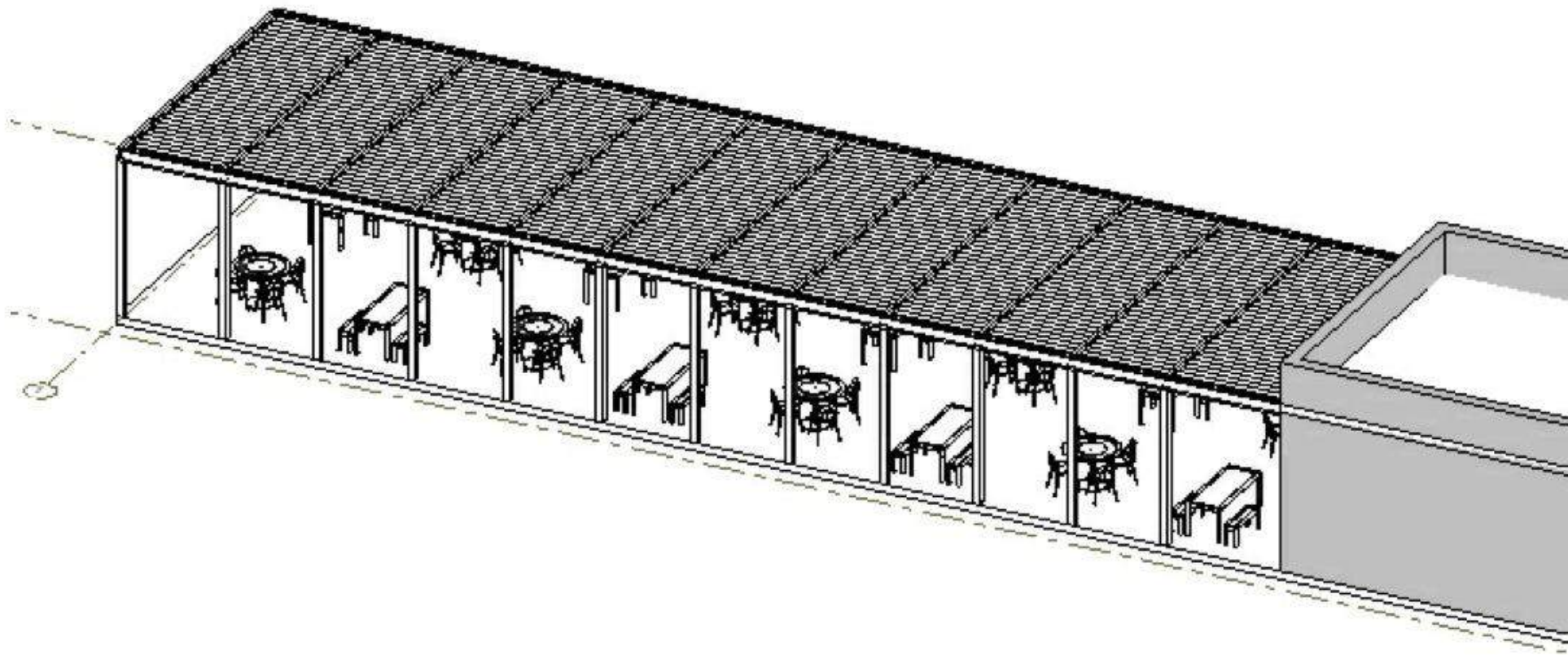
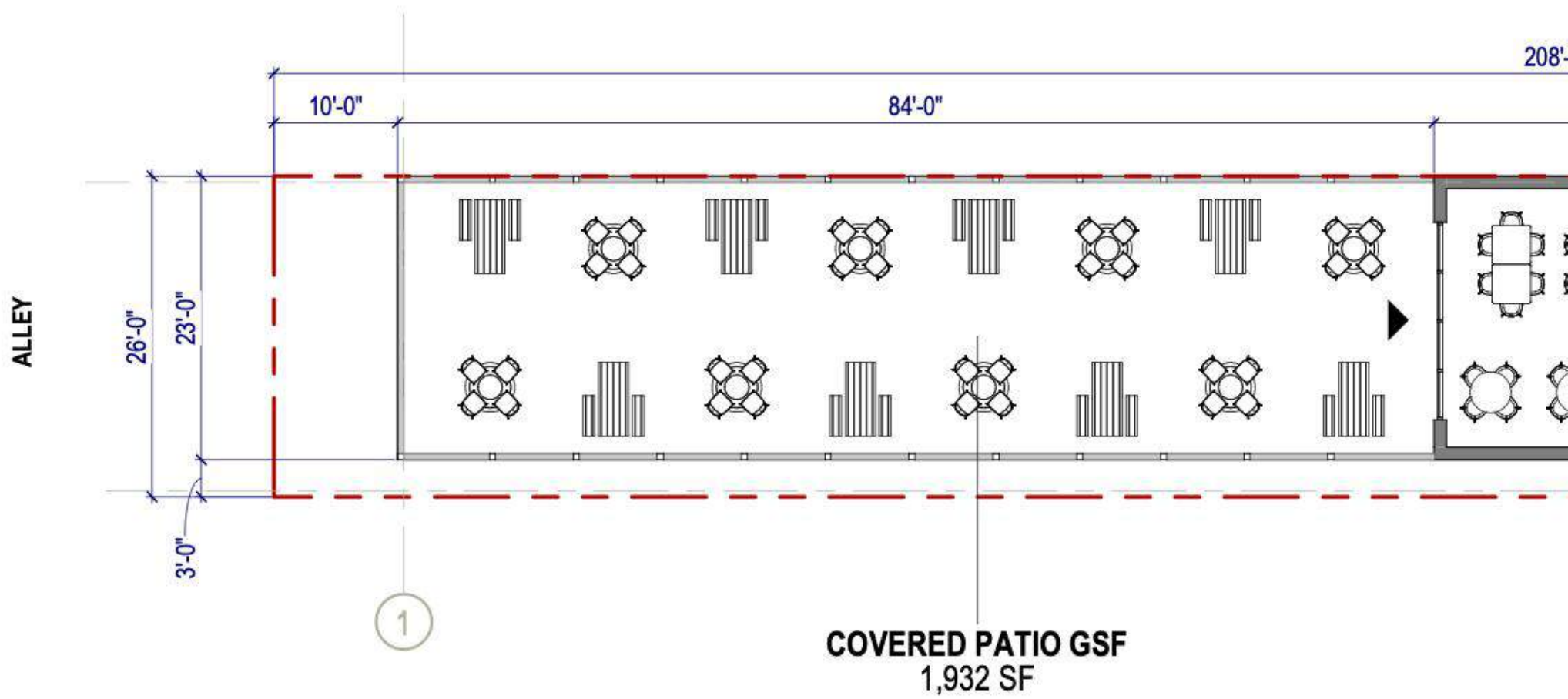

**SCHEMATIC 3D VIEW**

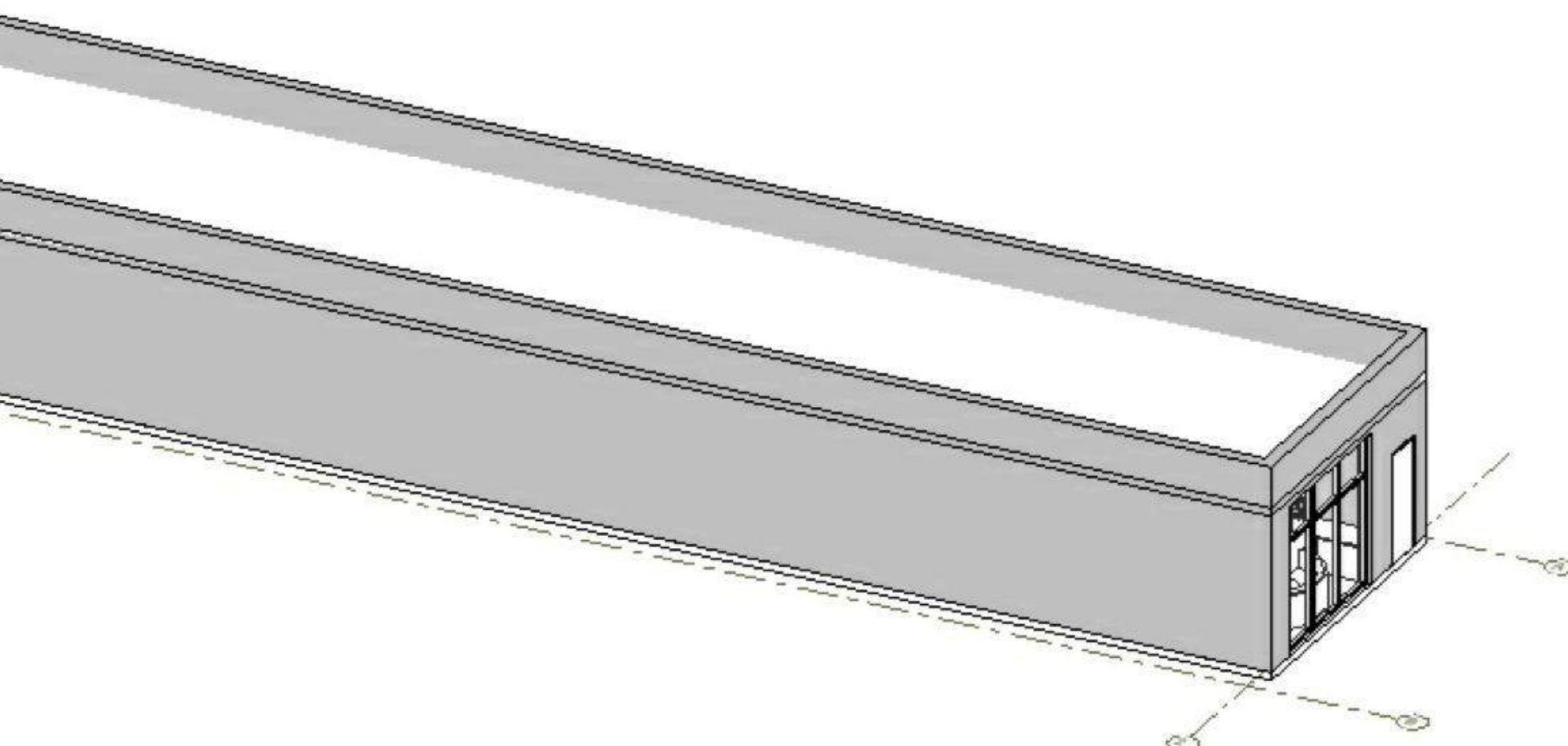
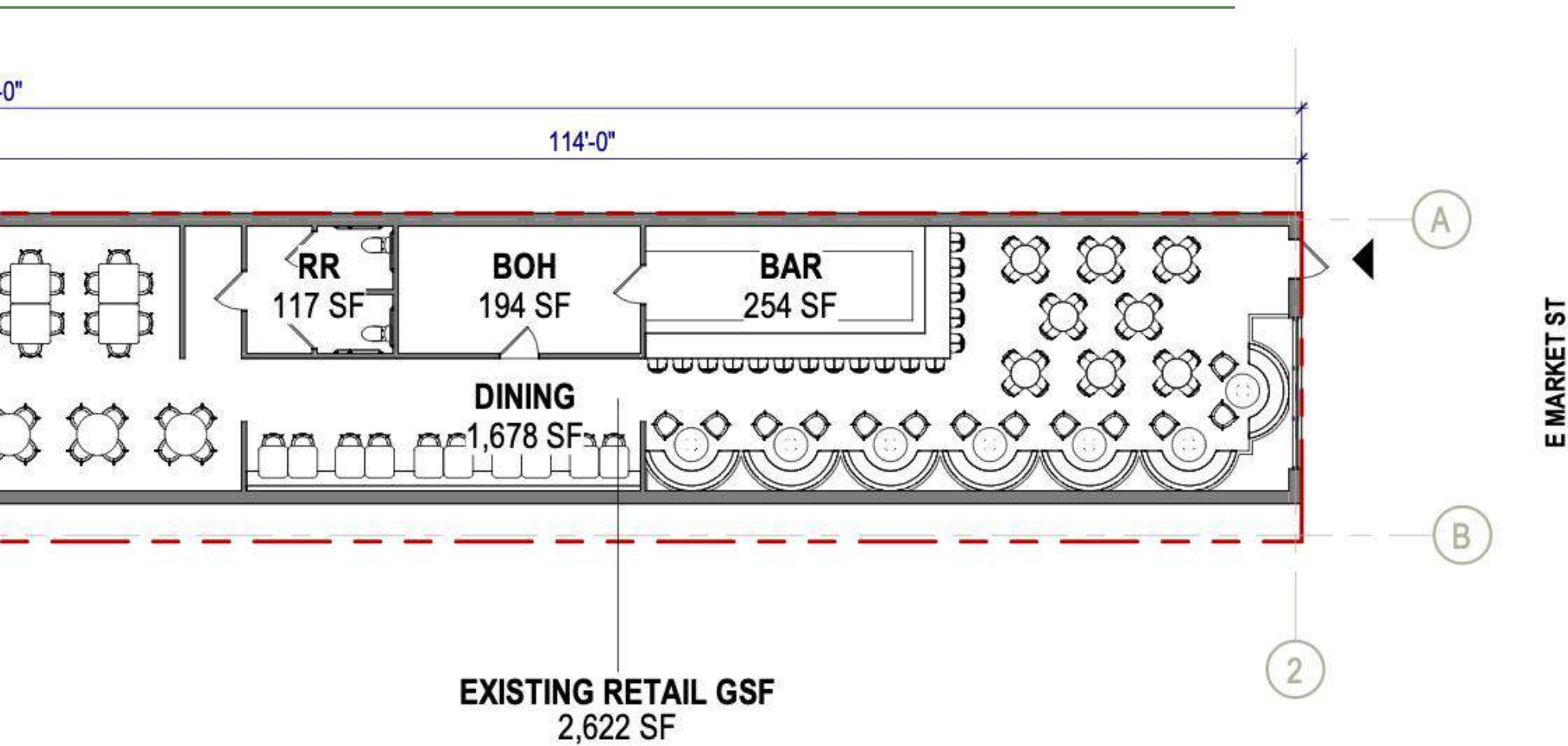















O'SHEA'S  
PUBLIC HOUSE

PATRICK O'SHEA'S  
O'SHEA'S PUBLIC HOUSE

21 MAIN PLACE

OLD FORESTER  
DISTILLERY CO.

DULUTH  
CASINO

DISTIL

HOWE  
BRASS BOWLS  
AVAILABLE  
\$1,999 UP  
\$2,999 UP  
\$3,999 UP  
\$4,999 UP

THE OLD FORESTER  
DISTILLERY CO.

DULUTH TRAIN

# Hospitality Driven Streetscapes

Award-winning national operators such as The Aparium Group, Bunkhouse Hotels, Hilton, and Marriott are taking NuLu to the next level, triggering significant appreciation to local real estate in the neighborhood.



📍 Hotel Anomalie: 1 Block



📍 Tempo by Hilton: 1 Block



📍 AC Hotel: 1 Block



📍 Hotel Genevieve by Bunkhouse: 1 Block



**Proven Demand**  
National Tenants  
about to Open



**Most Prime Location**  
Middle of  
Market Street



**Critical Mass Secured**  
Years of Negotiation  
& Planning

# *Hotel Anomalie*

📍 615 - 625 East Market Street, Louisville, KY, 40202

Set to debut in late 2025, the ~\$85m Hotel Anomalie will attract a new wave of visitors while sparking a transformation with vibrant streetscapes, booming tourism, and major institutional investment.





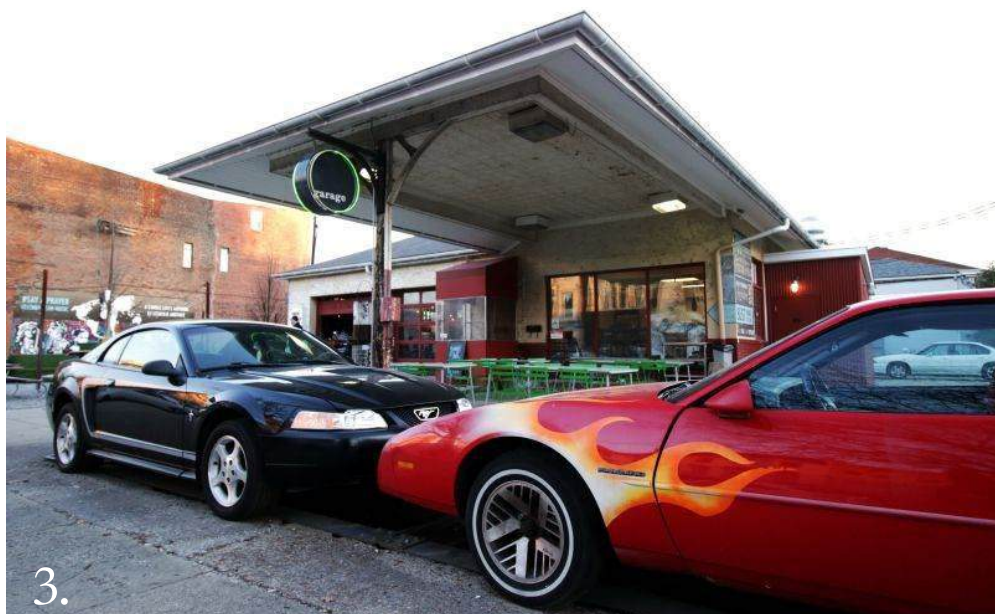



Residential · Retail · Office · Hospitality · Entertainment · Restaurants

### 1. Sake A Go Go

The latest brain-child from Kevin Grainger, this Asian eatery brings the east to Louisville

### 2. Goodwood Brewery

This intimate, laid-back joint serves microbrews on tap & offers a yoga class twice a month

### 3. Garage Bar

Hip bar & eatery in a former garage for brick-oven pies & southern chow featuring a large patio

### 4. NuLu Marketplace North

A three story building containing over 66k SqFt of restaurants, retail, and entertainment

### 5. Butchertown Grocery

A European-style bakery that makes everything in-house with high-quality ingredients in Louisville.

### 6. Martin on Main

Stylish and sophisticated apartments designed to enjoy the historic Butchertown and NuLu areas

### 7. Whiskey Thief

Whiskey Thief is a destination unlike any other on Kentucky's famed Bourbon Trail.

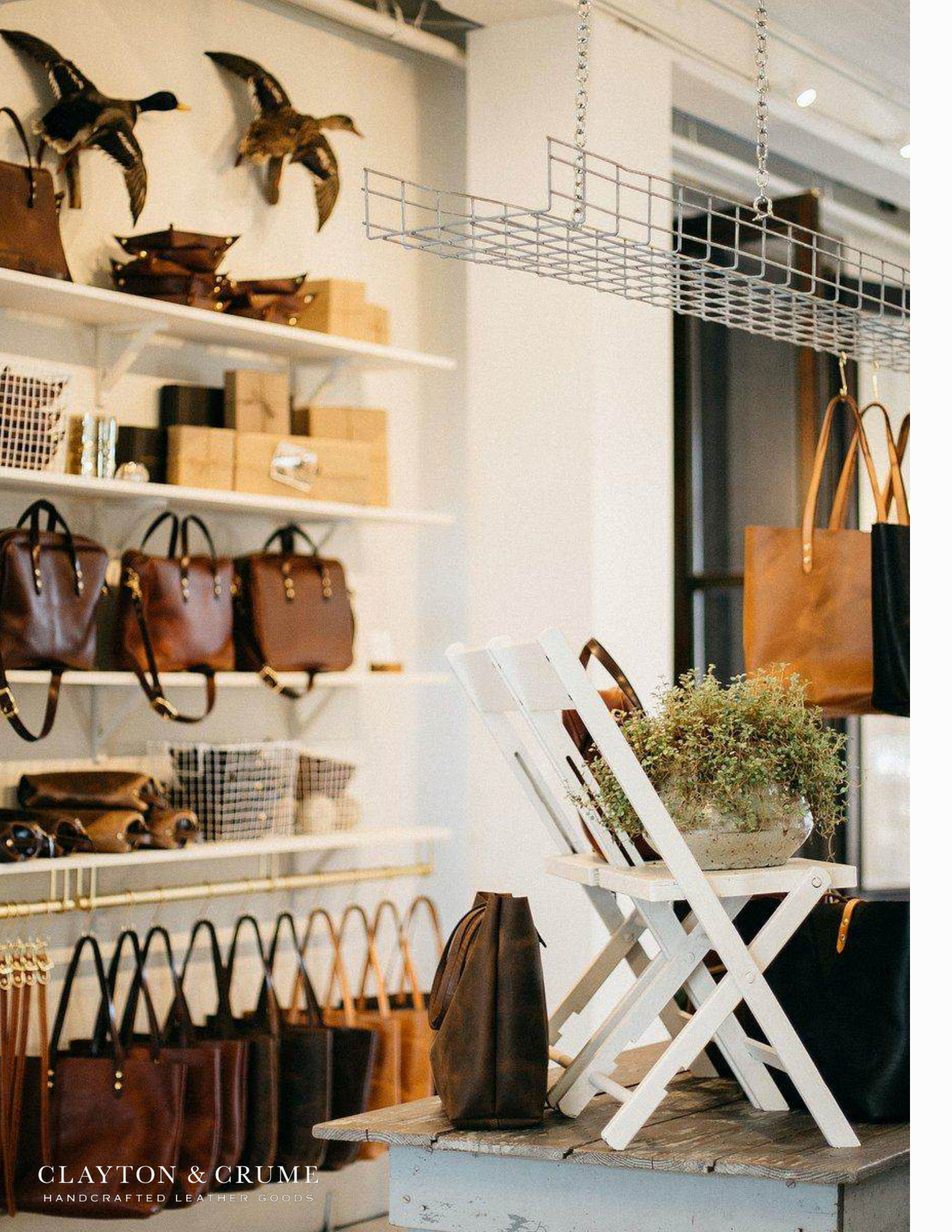

CLAYTON & CRUME  
HANDCRAFTED LEATHER GOODS



The finest leathers forged in  
the heart of bourbon country  
by Clayton & Crume

# Local Crafts

NuLu is a bustling hub where creativity  
meets commerce. From bourbon to  
leather goods, passion lives here.



# Bourbonism

Bringing over \$9 billion a year to Kentucky's economy, NuLu attracts visitors from all over the world to experience the best of Kentucky bourbon.

Distillery

100,000 Sqft Expansion

## Angel's Envy Distillery

500 E Main St, Louisville  
KY 40202



Distillery

100,000 Sqft Expansion

## Rabbit Hole

711 E Jefferson St, Louisville  
KY 40202



Bar & Music Venue

Bob Dylan's Bourbon - Heaven's Door

## The Last Refuge

600 E Market St Louisville  
KY 40202





# Premium Tenant Space Just For You

**291 SF**

Smallest Space Available

**13.5K SF**

Largest Space Available

**Negotiable**

Price Per Square Foot



## Hotel Marty

291 SqFt - 1151 SF Available

📅 2024

🏢 F&B/Retail & Office

🏗️ New-Build & Renovation



## The Billy Goat

5,422 SF Available

📅 2024

🏢 F&B/Retail

🏗️ New-Build

# Alternative Leasing Opportunities



## Sunday School

13.5K SF Available

📅 2024

🏢 F&B/Retail

🏗️ New-Build & Renovation



## The Zen

985 SF Available

📅 2024

🏢 F&B/Retail

🏗️ New-Build & Renovation



## Gateway to NuLu

4,479 - 9,477 SF Available

📅 2024

🏢 F&B, Office & Day Care

🏗️ Redevelopment

Reach out to [info@zyyo.com](mailto:info@zyyo.com) for more information

# 614 IVY

614 East Market,  
Louisville, Kentucky 40202

**Zyzo**

NuLu Crossing Leasing Brochure  
2024 Zyzo. Privileged and Confidential

NY / KY  
Kendrick Berman  
Kendrick@zyzo.com  
516-924-1708